

# A Miniature MMIC Double Doubly Balanced Mixer Using Lumped Dual Balun for High Dynamic Receiver Application

Hwann-Kaeo Chiou and Hao-Hsiung Lin

**Abstract**—A simple dual-balun structure is proposed for a miniature monolithic microwave integrated circuit (MMIC) double doubly balanced mixer (DDBM) design. The dual balun is realized by using two out-of-phase power splitters in parallel, which are then applied in a DDBM mixer. The measured conversion loss of the mixer is less than 10 dB for a radio frequency (RF) bandwidth of 2–5.5 GHz and fixed intermediate frequency (IF) output frequency of 2 GHz. The mixer achieves a high input IP<sub>3</sub> of 24 dBm and a 1-dB compression input power of 13 dBm at 17-dBm local oscillator (LO) drive. The chip area of mixer is less than  $1.0 \times 1.4 \text{ mm}^2$ , which is the smallest size ever reported for monolithic DDBM mixers.

## I. INTRODUCTION

**M**IXERS with low intermodulation products (IMP) and a high third-order intercept (IP<sub>3</sub>) point are the key components of receivers with a high dynamic range. So far, the field-effect transistor (FET) resistive mixer owns the highest IP<sub>3</sub> performance. However, its operation theory and design guidelines are not well understood yet [1]. Double doubly balanced mixers (DDBM) are another candidate for high dynamic range applications, and the operation theory is thoroughly studied. Furthermore, it is the only mixer that can have its radio frequency (RF) and intermediate frequency (IF) bandwidths overlap and still maintain isolation between its RF, IF, and local oscillator (LO) signals. Most of the DDBM designs require separate RF, LO, and IF baluns and doubling diodes, and are realized using hybrid implementation [1]. These mixers are bulky, nonplanar, and not suitable to the conventional planar monolithic microwave integrated circuit (MMIC) process. So far, there have been very few studies on MMIC DDBM. Eisenberg *et al.* realized a wide bandwidth uniplanar MMIC DDBM [2]. The baluns of this mixer were built by combining coplanar waveguides, slot lines, and coplanar stripes. However, these Marchand baluns are too large to be commercialized. Another X-band MMIC DDBM for high dynamic receiver applications was reported in [3]. Its balun structure is a lumped-element 180° hybrid which is analogous to the ratrace circuit. This mixer is composed of 15 inductors and 18 capacitors and with a chip size as large as  $2.5 \times 2.7 \text{ mm}^2$ . In this letter, a simple dual balun structure is first proposed for miniature MMIC DDBM design. Only ten

Manuscript received March 6, 1997. This work was supported by the National Science Council of R.O.C. under Contract NSC-85-2622-E-002-009.

The authors are with the Department of Electrical Engineering, National Taiwan University, Taipei, Taiwan, R.O.C.

Publisher Item Identifier S 1051-8207(97)05420-2.

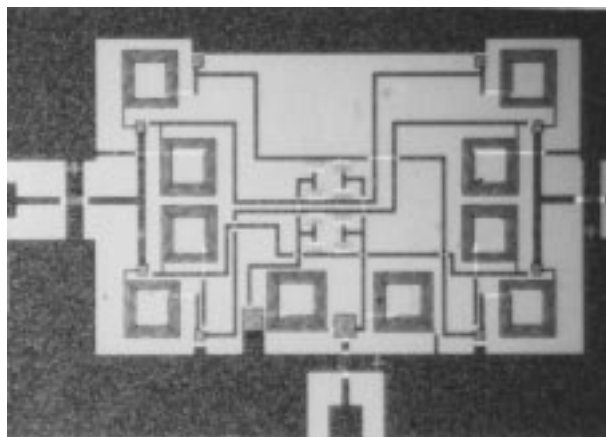
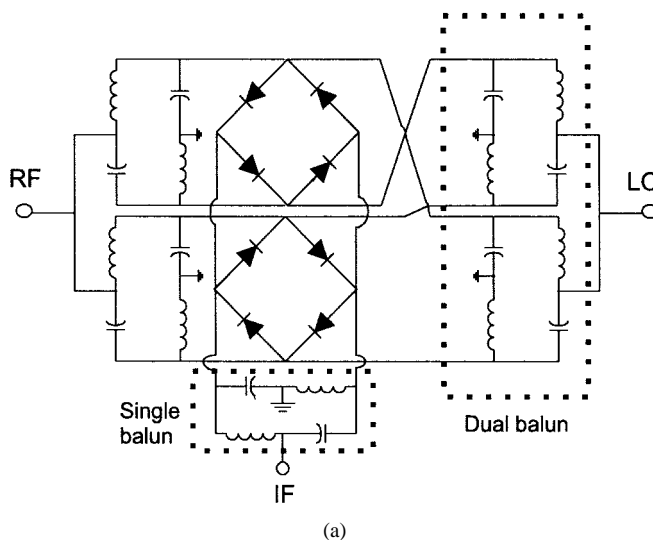

Fig. 1. (a) The circuit schematic diagram and (b) photograph of the lumped MMIC DDBM.

inductors and ten capacitors are used to implement the whole circuit. The chip size of the DDBM operated at 5 GHz is less than  $1.0 \times 1.4 \text{ mm}^2$ . The designed mixer maintains all of the specifications of the conventional DDBM. Many applications in the low microwave band are expected.

## II. DUAL BALUN DESIGN

Fig. 1 shows the schematic diagram and photograph of the DDBM. The mixer consists of two dual baluns for LO and

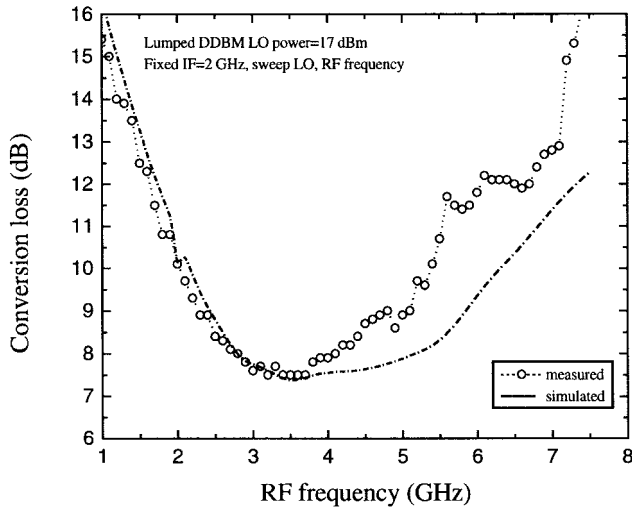

Fig. 2. Conversion loss of the DDBM, with a fixed IF frequency of a 2 GHz.

RF inputs, one single balun for IF output, and two ring diode quads. The key component of DDBM is the dual balun circuit used instead of the single balun using in the conventional ring-type DBM design. The dual balun is realized with two out-of-phase power splitters in parallel. Each out-of-phase power splitter is composed of one high-pass filter and one low-pass filter connected in parallel. For an ideal balun, the output ports share equal power but with  $180^\circ$  phase shift. In addition, the dual balun also acts like an impedance transformer. The impedance of the dual balun  $Z_t$  is given by

$$Z_t = \sqrt{Z_o \times Z_d} \quad (1)$$

where  $Z_o$  and  $Z_d$  are characteristic and diode impedance, respectively. In our design, the second-order filter composed of only one inductor and one capacitor is adopted for minimizing the number of circuit elements. The relations between the values of  $Z_t$ ,  $L$ , and  $C$  is described in the following equations:

$$\begin{aligned} L &= \frac{Z_t}{\omega}, \\ C &= \frac{1}{\omega Z_t} \end{aligned} \quad (2)$$

where  $\omega$  is the center frequency of the balun.

In this simple design, the dual balun outputs have exactly equal power only at the center frequency. The amplitude error degrades outside the center frequency. Basically, this drawback can be improved by using higher order filter topology. However, it will pay the penalty of chip area increase due to the extra lumped elements.

### III. MMIC MIXER DESIGN

The  $N$ -implanted diode is chosen to fabricate the MMIC DDBM diode quad. The size of each diode is  $1.0 \mu\text{m} \times 25 \mu\text{m}$ . These diodes have a series resistance about  $32 \Omega$  and a zero bias junction capacitance about  $57.5 \text{ fF}$ , which corresponds to an  $f_T$  of  $77 \text{ GHz}$ . The available LO power level of these ring diode quads is from 12 to 20 dBm. The LO and RF dual balun consists of four 3-nH inductors and four 0.27-pF capacitors, and corresponds to a 5-GHz center frequency. The IF balun

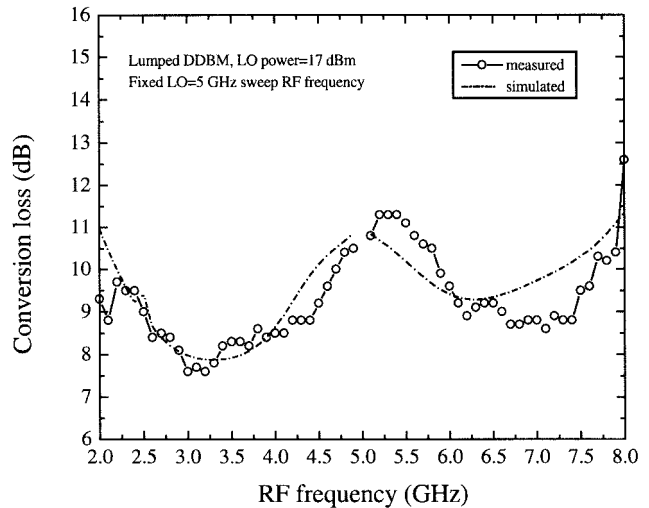

Fig. 3. Conversion loss of the DDBM, with a fixed LO frequency of 5 GHz.

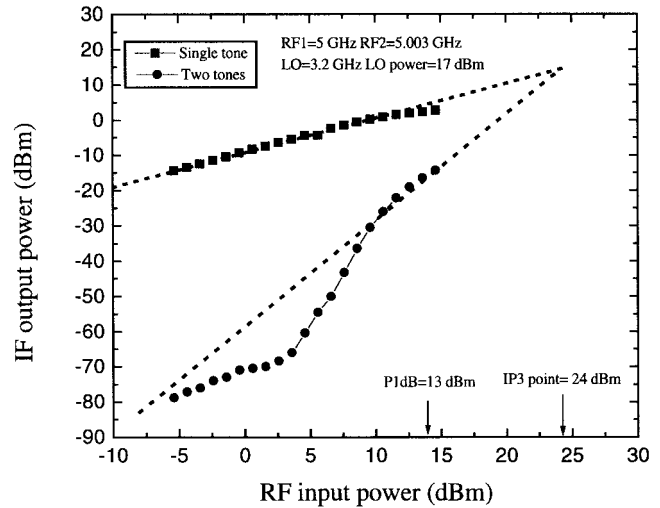

Fig. 4. First- and third-order IF power outputs as a function of RF input power, with the mixer operated as a down converter.

consists of two 4-nH inductors and two 1.2-pF capacitors, and has a center frequency of 2 GHz. These baluns and the double-ring diodes are connected to form a complete DDBM circuit. The chip size is only  $1.0 \times 1.4 \text{ mm}^2$ . Compared to the traditional single- or double-balanced mixer, the size has been reduced by several times.

### IV. MEASURED RESULTS

As shown in Fig. 2, the conversion loss is measured at a fixed IF frequency of 2 GHz with a 17-dBm LO drive. The obtained conversion loss is below 10 dB within a RF bandwidth from 2 to 5.5 GHz. The LO/RF and LO/IF isolations exceed 20 dB when LO frequency varies from 3.2 to 6.4 GHz. Fig. 3 shows the conversion loss at a fixed LO frequency of 5 GHz. As can be seen, the measured data are in good agreements with the predicted curve. The RF bandwidth with a conversion loss less than 11 dB is from 2 to 8 GHz. The RF/IF bandwidth overlapping is also demonstrated in this measurement. Notice that the IF frequency is up to 3 GHz when the RF frequency

is 2 GHz. Fig. 4 shows the IF output power and its third-order product versus RF input power. The observed third-order intercept point is as high as 24 dBm under the 17-dBm LO drive. This result is comparable to the resistive FET mixers which have the highest IP3 performance among the mixers.

#### V. CONCLUSIONS

A new planar DDBM suitable for MIC and MMIC fabrication has been presented. The MMIC DDBM exhibits wide bandwidth, RF/IF bandwidths overlapping, high isolations, and high P1 dB and IP3 characteristics. The most promising feature is its compact size and high dynamic range that allows the circuit to be applied in low microwave band such as wireless communication system.

#### ACKNOWLEDGMENT

The GaAs foundry services were provided by Chip Implementation Center of NSC and Hexawave Photonic System Inc.

#### REFERENCES

- [1] S. A. Maas, *Microwave Mixers*, 2nd ed. Norwood, MA: Artech House, 1992, ch. 9, p. 344.
- [2] J. A. Eisenberg, J. S. Panelli, and W. Ou, "Slotline and coplanar waveguide team to realize a novel MMIC double balanced mixer," *Microwave J.*, pp. 123-131, Sept. 1992.
- [3] T. N. Ton, G. S. Dow, T. H. Chen, M. Lacon, T. S. Lin, S. Bui, and D. Yang "An X-band monolithic double double-balanced mixer for high dynamic receiver application," in *IEEE MTT-S Dig.*, 1990, pp. 197-200.