

## The Scope and Limitations of 1,3-Stannyl Shift-Promoted Intramolecular Cyclizations of $\alpha$ -Stannyl Radicals with a Formyl Group

Shau-Hua Ueng, Ming-Jen Chen, Shu-Fang Chu, Yar-Fang Shao, Gang-Ting Fan, Sheng-Yueh Chang, and Yeun-Min Tsai\*

Department of Chemistry, National Taiwan University, Taipei, Taiwan 106, Republic of China

ymtsai@ntu.edu.tw

Received October 19, 2005

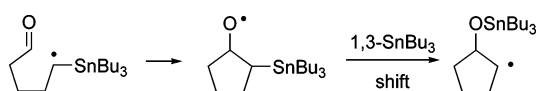

$\alpha$ -Tributylstannyl radicals can be generated from the corresponding bromides or xanthates. These radicals undergo efficient intramolecular 1,5-cyclizations with a formyl group. The resulting  $\beta$ -stannyl alkoxy radicals proceed through a 1,3-stannyl shift from carbon to oxygen to afford  $\beta$ -stannyloxy radicals. This novel rearrangement is most likely irreversible and serves as a driving force to promote the cyclizations. Although the cyclization rates can be accelerated when the formyl group carries  $\alpha$ -dimethyl substituents, unfortunately  $\beta$ -scission of the alkoxy radicals becomes competitive with the 1,3-stannyl shift. The  $\beta$ -stannyloxy radicals can be employed in further cyclizations to obtain tandem cyclization products.

### Introduction

Radical reactions have emerged as useful synthetic tools in recent years.<sup>1</sup> Among the radical reactions, the 5-hexenyl radical cyclization system is widely received as an important avenue to construct five-membered ring skeletons. In contrast, although the 4-formylbutyl and 5-formylpentyl radicals (Scheme 1) can also undergo cyclizations to construct cyclopentane and cyclohexane rings<sup>2</sup> with rates ( $k_1 = 8.7 \times 10^5 \text{ s}^{-1}$ ,  $k_2 = 1.0 \times 10^6 \text{ s}^{-1}$  at 80 °C)<sup>2a</sup> comparable to those of the 5-*exo* cyclization of 5-hexenyl radical ( $k_{\text{exo}} = 1.3 \times 10^6 \text{ s}^{-1}$  at 80 °C),<sup>3</sup> ring openings of the cyclized cyclopentyloxy and cyclohexyloxy radicals proceed with a much faster pace ( $k_{-1} = 4.7 \times 10^8 \text{ s}^{-1}$ ,  $k_{-2} = 1.1 \times 10^7 \text{ s}^{-1}$  at 80 °C).<sup>2a,b</sup> However, the cyclizations can be irreversible in highly substituted systems<sup>4</sup> and quite efficient when assisted by the *gem*-dialkyl effect.<sup>5,6</sup> Nonetheless, the inherent reversible property still renders the carbonyl radical cyclizations a less attractive possibility, so far as the cyclization is concerned.<sup>7</sup>

### SCHEME 1

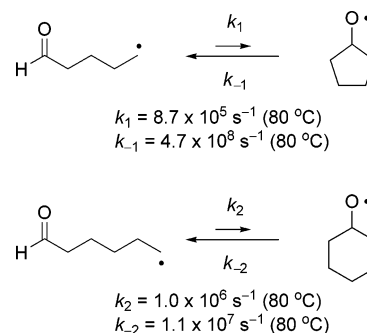

To cope with this problem, there were several methods developed to trap the cyclized alkoxy radical irreversibly so that the reaction could be driven toward cyclization. Thus, Batey

\* Corresponding author. Telephone: 886-2-3366-1651. Fax: 886-2-2363-6359.

(1) (a) Fossey, J.; Lefort, D.; Sorba, J. *Free Radicals in Organic Chemistry*; John Wiley & Sons: New York, 1995. (b) Giese, B.; Kopping, B.; Göbel, T.; Dickhaut, J.; Thoma, G.; Kulicke, K. J.; Trach, F. *Org. React.* **1996**, *48*, 301–856. (c) *Radicals in Organic Synthesis*; Renaud, P., Sibi, M. P., Eds.; Wiley-VCH: Weinheim, 2001.

(2) (a) Beckwith, A. L. J.; Hay, B. P. *J. Am. Chem. Soc.* **1989**, *111*, 230–234. (b) Beckwith, A. L. J.; Hay, B. P. *J. Am. Chem. Soc.* **1989**, *111*, 2674–2681. (c) Beckwith, A. L. J.; Raner, K. D. *J. Org. Chem.* **1992**, *57*, 4954–4962.

(3) Chatgililoglu, C.; Ingold, K. U.; Scaiano, J. C. *J. Am. Chem. Soc.* **1981**, *103*, 7739–7742.

(4) (a) Tsang, R.; Fraser-Reid, B. *J. Am. Chem. Soc.* **1986**, *108*, 2116–2117. (b) Tsang, R.; Fraser-Reid, B. *J. Am. Chem. Soc.* **1986**, *108*, 8102–8104. (c) Tsang, R.; Dickson, J. K., Jr.; Pak, H.; Walton, R.; Fraser-Reid, B. *J. Am. Chem. Soc.* **1987**, *109*, 3484–3486. (d) Fraser-Reid, B.; Vite, G. D.; Yeung, B.-W. A.; Tsang, R. *Tetrahedron Lett.* **1988**, *29*, 1645–1648. (e) Dickson, J. K., Jr.; Tsang, R.; Llera, J. M.; Fraser-Reid, B. *J. Org. Chem.* **1989**, *54*, 5350–5356. (f) Walton, R.; Fraser-Reid, B. *J. Am. Chem. Soc.* **1991**, *113*, 5791–5799. (g) Knapp, S.; Gibson, F. S.; Choe, Y. H. *Tetrahedron Lett.* **1990**, *31*, 5397–5400. (h) Knapp, S.; Gibson, F. S. *J. Org. Chem.* **1992**, *57*, 4802–4809.

(5) Batey, R. A.; MacKay, D. B. *Tetrahedron Lett.* **1998**, *39*, 7267–7270.

## SCHEME 2

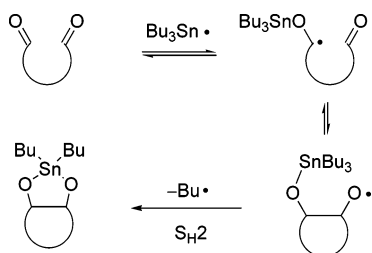

and MacKay successfully employed phenylsilane to selectively transfer hydrogen atom to the oxygen radical instead of the carbon radical.<sup>5</sup> Triethylborane was found to be able to improve the efficiency of the carbonyl radical cyclizations.<sup>8</sup> The ability of triethylborane to trap the intermediate alkoxy radical probably plays an important role.<sup>8b</sup> Kim and Oh reported that triphenylphosphine was able to trap the cyclized alkoxy radicals and subsequently lose triphenylphosphine oxide to afford five- and six-membered ring radicals.<sup>9</sup> In an intramolecular pinacol coupling of 1,5- and 1,6-dicarbonyl compounds using tributyltin hydride (Scheme 2), Hays and Fu found that a tributyltin moiety served as an intramolecular trap of the alkoxy radical through a fast  $S_N2$  pathway and releasing a butyl radical.<sup>10</sup>

In the case of acylgermanes<sup>11</sup> and thio- and seleno-esters<sup>12</sup> (Scheme 3), the cyclized alkoxy radicals were reported to undergo  $\beta$ -scissions to afford cyclic ketones. In contrast, the cyclized alkoxy radical intermediates in acylsilanes<sup>13,14</sup> were found to proceed irreversibly through a radical-Brook rearrangement<sup>15,16</sup> to generate silyloxy-substituted cyclic radicals. Interestingly, the acylsilane system is formally an equivalent of the 4-formylbutyl and 5-formylpentyl radical cyclizations.

A few years ago, we reported the cyclization of  $\alpha$ -stannyl bromide **1** (Scheme 4) using tributyltin hydride to give cyclopentanol.<sup>17</sup> This process involves the generation of  $\alpha$ -stannyl radical **2** that cyclizes to afford  $\beta$ -stannyl alkoxy radical **3**.<sup>18</sup> A key 1,3-stannyl shift occurs to generate  $\beta$ -stannyloxy-substituted

## SCHEME 3

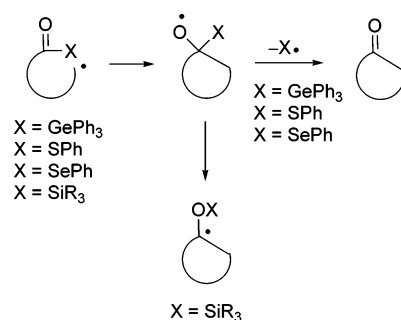

## SCHEME 4

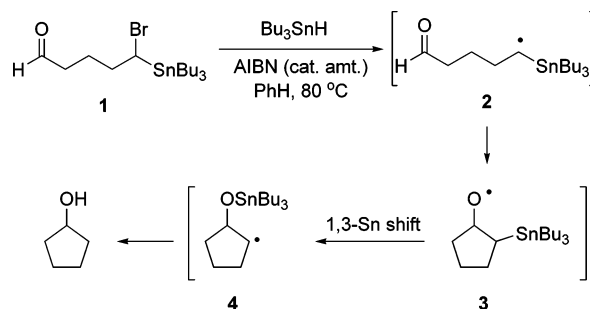

radical **4**.<sup>15e,19–22</sup> Subsequent hydrogen atom abstraction of radical **4** from tributyltin hydride and destannylation give cyclopentanol. A bond energy difference of 19 kcal/mol between the stronger O–Sn bond ( $\sim 84$  kcal/mol)<sup>23</sup> and weaker C–Sn

(6) For the *gem*-dialkyl effect, see: (a) Beckwith, A. L. J.; Lawrence, T. *J. Chem. Soc., Perkin Trans. 2* **1979**, 1535–1539. (b) Capon, B.; McManus, S. P. *Neighboring Group Participation*; Plenum: New York, 1976; Vol. 1, pp 58–75. (c) Kirby, A. J. *Adv. Phys. Org. Chem.* **1980**, *17*, 183–278.

(7) For the application of radical cyclizations of carbonyl group in ring expansion reactions, see: (a) Dowd, P.; Zhang, W. *Chem. Rev.* **1993**, *93*, 2091–2115. (b) Yet, L. *Tetrahedron* **1999**, *55*, 9349–9403. (c) Zhang, W. In *Radicals in Organic Synthesis*; Renaud, P., Sibi, M. P., Eds.; Wiley-VCH: Weinheim, 2001; Vol. 2, pp 234–245. (d) Zhang, W. *Curr. Org. Chem.* **2002**, *6*, 1015–1029.

(8) (a) Clive, D. L. J.; Postema, M. H. D. *J. Chem. Soc., Chem. Commun.* **1993**, 429–430. (b) Devin, P.; Fensterbank, L.; Malacria, M. *Tetrahedron Lett.* **1998**, *39*, 833–836. (c) Devin, P.; Fensterbank, L.; Malacria, M. *Tetrahedron Lett.* **1999**, *40*, 5511–5514. (d) Chareyron, M.; Devin, P.; Fensterbank, L.; Malacria, M. *Synlett* **2000**, 83–85. (e) Yoshimitsu, T.; Tsunoda, M.; Nagaoka, H. *J. Chem. Soc., Chem. Commun.* **1999**, 1745–1746. (f) Yoshimitsu, T.; Arano, Y.; Nagaoka, H. *J. Org. Chem.* **2003**, *68*, 625–627. (g) Yoshimitsu, T.; Makino, T.; Nagaoka, H. *J. Org. Chem.* **2003**, *68*, 7548–7550. (h) Yoshimitsu, T.; Arano, Y.; Nagaoka, H. *J. Org. Chem.* **2005**, *70*, 2342–2345. (i) Yoshimitsu, T.; Arano, Y.; Nagaoka, H. *J. Am. Chem. Soc.* **2005**, *127*, 11610–11611.

(9) Kim, S.; Oh, D. H. *Synlett* **1998**, 525–527.

(10) (a) Hays, D. S.; Fu, G. C. *J. Am. Chem. Soc.* **1995**, *117*, 7283–7284. (b) Hays, D. S.; Fu, G. C. *J. Org. Chem.* **1998**, *63*, 6375–6381.

(11) (a) Curran, D. P.; Liu, H. *J. Org. Chem.* **1991**, *56*, 3463–3465. (b) Curran, D. P.; Palovich, M. *Synlett* **1992**, 631–632. (c) Curran, D. P.; Diederichsen, U.; Palovich, M. *J. Am. Chem. Soc.* **1997**, *119*, 4797–4804. (d) Diederichsen, U.; Curran, D. P. *J. Organomet. Chem.* **1997**, *531*, 9–12.

(12) (a) Kim, S.; Jon, S. Y. *J. Chem. Soc., Chem. Commun.* **1996**, 1335–1336. (b) Kim, S.; Jon, S. Y. *J. Chem. Soc., Chem. Commun.* **1998**, 815–816. (c) Kim, S.; Jon, S. Y. *Tetrahedron Lett.* **1998**, *39*, 7317–7320.

(13) (a) Tsai, Y.-M.; Cherng, C.-D. *Tetrahedron Lett.* **1991**, *32*, 3515–3518. (b) Tsai, Y.-M.; Tang, K.-H.; Jiaang, W.-T. *Tetrahedron Lett.* **1993**, *34*, 1303–1306. (c) Curran, D. P.; Jiaang, W.-T.; Palovich, M.; Tsai, Y.-M. *Synlett* **1993**, 403–404. (d) Tsai, Y.-M.; Chang, S.-Y. *J. Chem. Soc., Chem. Commun.* **1995**, 981–982. (e) Chuang, T.-H.; Fang, J.-M.; Jiaang, W.-T.; Tsai, Y.-M. *J. Org. Chem.* **1996**, *61*, 1794–1805. (f) Tsai, Y.-M.; Tang, K.-H.; Jiaang, W.-T. *Tetrahedron Lett.* **1996**, *37*, 7767–7770. (g) Tsai, Y.-M.; Nieh, H.-C.; Pan, J.-S.; Hsiao, D.-D. *J. Chem. Soc., Chem. Commun.* **1996**, 2469–2470. (h) Chang, S.-Y.; Jiaang, W.-T.; Cherng, C.-D.; Tang, K.-H.; Huang, C.-H.; Tsai, Y.-M. *J. Org. Chem.* **1997**, *62*, 9089–9098. (i) Jiaang, W.-T.; Lin, H.-C.; Tang, K.-H.; Chang, L.-B.; Tsai, Y.-M. *J. Org. Chem.* **1999**, *64*, 618–628. (j) Huang, C.-H.; Chang, S.-Y.; Wang, N.-S.; Tsai, Y.-M. *J. Org. Chem.* **2001**, *66*, 8983–8991. (k) Tang, K.-H.; Liao, F.-Y.; Tsai, Y.-M. *Tetrahedron* **2005**, *61*, 2037–2045.

(14) For recent reviews about acylsilanes, see: (a) Ricci, A.; Degl'Innocenti, A. *Synthesis* **1989**, 647–660. (b) Page, P. C. B.; Klair, S. S.; Rosenthal, S. *Chem. Soc. Rev.* **1990**, *19*, 147–195. (c) Cirillo, P. F.; Panek, J. S. *Org. Prep. Proced. Int.* **1992**, *24*, 553–582. (d) Page, P. C. B.; McKenzie, M. J.; Klair, S. S.; Rosenthal, S. In *The Chemistry of Organic Silicon Compounds*; Rappoport, Z., Apeloig, Y., Eds.; John Wiley & Sons: New York, 1998; Vol. 2, Chapter 27, pp 1599–1665. (e) Bonini, B. F.; Comes-Franchini, M.; Fochi, M.; Mazzanti, G.; Ricci, A. *J. Organomet. Chem.* **1998**, *567*, 181–189.

(15) (a) Dalton, J. C.; Bourque, R. A. *J. Am. Chem. Soc.* **1981**, *103*, 699–700. (b) Harris, J. M.; MacInnes, I.; Walton, J. C.; Maillard, B. *J. Organomet. Chem.* **1991**, *403*, C25–C28. (c) Tsai, Y.-M.; Ke, B.-W. *J. Chin. Chem. Soc. (Taipei)* **1993**, *40*, 641–642. (d) Robertson, J.; Burrows, J. N. *Tetrahedron Lett.* **1994**, *35*, 3777–3780. (e) Schiesser, C. H.; Styles, M. L. *J. Chem. Soc., Perkin Trans. 2* **1997**, 2335–2340. (f) Paredes, M. D.; Alonso, R. *Tetrahedron Lett.* **1999**, *40*, 3973–3976. (g) Paredes, M. D.; Alonso, R. *J. Org. Chem.* **2000**, *65*, 2292–2304.

(16) For a recent review about Brook rearrangement, see: Moser, W. H. *Tetrahedron* **2001**, *57*, 2065–2084.

(17) Chang, S.-Y.; Shao, Y.-F.; Chu, S.-F.; Fan, G.-T.; Tsai, Y.-M. *Org. Lett.* **1999**, *1*, 945–948.

(18) For a novel 1,3-cyclization of  $\alpha$ -stannyl radical to carbonyl in ring expansion reactions, see: Nishida, A.; Takahashi, H.; Takeda, H.; Takada, N.; Yonemitsu, O. *J. Am. Chem. Soc.* **1990**, *112*, 902–904.

(19) For homolytic stannyl group transfers from carbon to oxygen, see: (a) Kim, S.; Lee, S.; Koh, J. S. *J. Am. Chem. Soc.* **1991**, *113*, 5106–5107. (b) Kim, S.; Lim, K. M. *J. Chem. Soc., Chem. Commun.* **1993**, 1152–1153. (c) Kim, S.; Lim, K. M. *Tetrahedron Lett.* **1993**, *34*, 4851–4854.

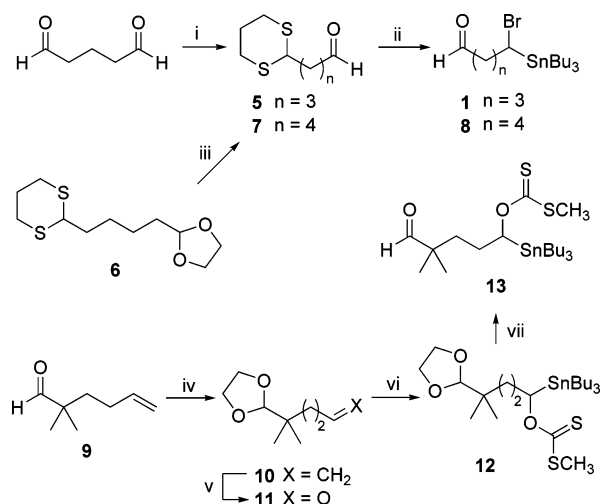
SCHEME 5<sup>a</sup>

<sup>a</sup> Reagents and conditions: (i) HS(CH<sub>2</sub>)<sub>3</sub>SH, BF<sub>3</sub>·OEt<sub>2</sub>, CH<sub>2</sub>Cl<sub>2</sub>, 0 °C (81% for **5**); (ii) (a) Bu<sub>3</sub>SnH, LDA, (b) Ph<sub>3</sub>P, CBr<sub>4</sub>, (c) CAN, CH<sub>3</sub>CN/H<sub>2</sub>O, -15 °C (56% for **1** and 42% for **8**); (iii) TsOH, H<sub>2</sub>O/THF, 65 °C (84% for **7**); (iv) HO(CH<sub>2</sub>)<sub>2</sub>OH, TsOH, PhH, 80 °C (69% for **10**); (v) (a) O<sub>3</sub>, NaHCO<sub>3</sub> (7 equiv), CH<sub>2</sub>Cl<sub>2</sub>, (b) Et<sub>3</sub>N (2 equiv) (80% for **11**); (vi) (a) Bu<sub>3</sub>SnH, LDA, THF, -78 °C, (b) CS<sub>2</sub>, -78 °C, (c) MeI, -78 °C to rt (67% for **12**); (vii) TsOH (1 equiv), HCHO (3 equiv), THF/H<sub>2</sub>O, 60 °C (90% for **13**).

bond (~65 kcal/mol)<sup>23</sup> presumably serves as the driving force for the key rearrangement that makes this carbonyl cyclization a success. Now, we wish to report our full investigation in this direction.

## Results and Discussion

**The Model System.** Our initial study was carried out using  $\alpha$ -bromostannanes **1** and **8** (Scheme 5). Bromide **1** was prepared from glutaric dialdehyde by first protecting one formyl group as 1,3-dithiane to give the monoaldehyde **5** (81%). Aldehyde **5** was then treated with tributyltin lithium,<sup>24</sup> and the resulting  $\alpha$ -stannyl alcohol obtained was converted to the corresponding bromide with carbon tetrabromide and triphenylphosphine.<sup>25</sup> Because of the presence of the nucleophilic sulfur atoms in the dithiane moiety at the other end, this bromide is not stable and should be used as soon as possible in the next step. Subsequent hydrolysis of the dithiane with ceric ammonium nitrate (CAN) in wet acetonitrile<sup>26</sup> afforded bromoaldehyde **1** in a 56% overall yield from aldehyde **5**. The homologous bromo aldehyde **8** was synthesized from aldehyde **7** in a 42% yield using similar

(20) For homolytic stannyl group transfers from oxygen to oxygen, see: (a) Alberti, A.; Hudson, A. *Chem. Phys. Lett.* **1977**, *48*, 331–333. (b) Barker, P. J.; Davies, A. G.; Hawari, J. A.-A.; Tse, M.-W. *J. Chem. Soc., Perkin Trans. 2* **1980**, 1488–1496. (c) Davies, A. G.; Tse, M.-W. *J. Organomet. Chem.* **1978**, *155*, 25–30. (d) Kim, S.; Koh, J. S. *J. Chem. Soc., Chem. Commun.* **1992**, 1377–1378. (e) Kim, S.; Do, J. Y.; Lim, K. M. *J. Chem. Soc., Perkin Trans. 1* **1994**, 2517–2518. (f) Kim, S.; Do, J. Y.; Lim, K. M. *Chem. Lett.* **1996**, 669–670.

(21) For homolytic stannyl group transfers involving nitrogen radicals, see: Kim, S.; Jung, M. S.; Cho, C. H.; Schiesser, C. H. *Tetrahedron Lett.* **2001**, *42*, 943–945.

(22) For theoretical studies about homolytic stannyl group translocations, see: (a) Kim, S.; Horvat, S. M.; Schiesser, C. H. *Aust. J. Chem.* **2002**, *55*, 753–755. (b) Matsubara, H.; Schiesser, C. H. *J. Org. Chem.* **2003**, *68*, 9299–9309.

(23) Jackson, R. A. *J. Organomet. Chem.* **1979**, *166*, 17–19.

(24) Still, W. C. *J. Am. Chem. Soc.* **1978**, *100*, 1481–1487.

(25) Torisawa, Y.; Shibasaki, M.; Ikegami, S. *Tetrahedron Lett.* **1981**, *22*, 2397–2400.

SCHEME 6

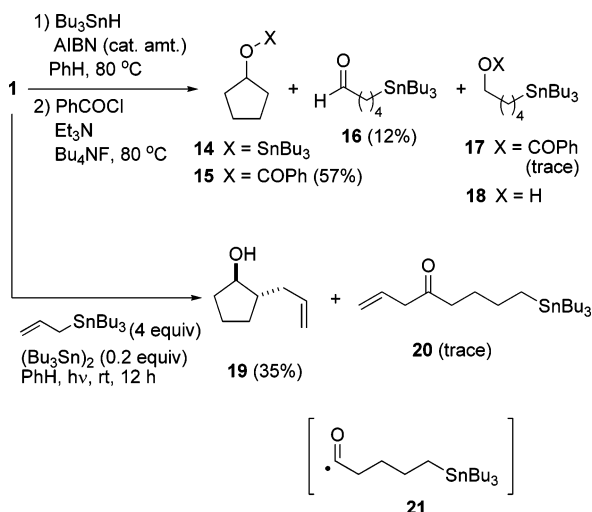

methods. The required aldehyde **7** was derived from the hydrolysis of 1,3-dioxolane **6**.<sup>27</sup>

The radical cyclization reactions were performed by slow addition of a benzene solution of tributyltin hydride and a catalytic amount of azobisisobutyronitrile (AIBN) to a refluxing benzene solution of the bromo aldehyde. For the reaction of bromo aldehyde **1** with tributyltin hydride (Scheme 6), we were never able to isolate the expected cyclopentyl tributyltin ether (**14**). Instead, we could isolate the destannylated product cyclopentanol. However, due to the volatility of cyclopentanol, the isolation yield was low. As shown in Scheme 6, we decided to trap the intermediate stannyl ether **14** by directly adding excess benzoyl chloride (5 equiv), triethylamine (4 equiv), and tetrabutylammonium fluoride (1 equiv) to the reaction mixture after the cyclization, and the resulting mixture was heated to 80 °C for 12 h. Benzoate **15** was isolated in a 57% yield along with 12% of the uncyclized straight reduction product **16** (12%). A trace amount of benzoate **17** was also detected. This material is most likely coming from benzoylation of alcohol **18** that is derived from further reduction of aldehyde **16** by tributyltin hydride.<sup>28</sup>

To demonstrate that the cyclization occurs through a 1,3-stannyl shift (Scheme 4), we treated bromo aldehyde **1** with allyltributyltin (4 equiv) to trap the  $\beta$ -stannyl radical intermediate **4**.<sup>29</sup> This reaction was initiated with a catalytic amount of hexabutyltin (0.2 equiv) and irradiated with long wavelength UV lamps at room temperature. Although the intermolecular radical trapping process is sluggish, we were able to isolate 35% of *trans*-2-allylcyclopentanol (**19**).<sup>30</sup> A trace amount of allyl ketone **20** was also obtained. The formation of **20** reflects the presence of a small fraction of acyl radical **21** coming from 1,5-hydrogen abstraction of  $\alpha$ -stannyl radical **2**.<sup>2b</sup> However, this experiment suggests that the predominant mode

(26) (a) Ho, T.-L.; Ho, H. C.; Wong, C. M. *J. Chem. Soc., Chem. Commun.* **1972**, 791–791. (b) Ho, H. C.; Ho, T.-L.; Wong, C. M. *Can. J. Chem.* **1972**, *50*, 2718–2721.

(27) Grigg, R.; Markandu, J.; Surendrakumar, S.; Thornton-Pett, M.; Warnock, W. J. *Tetrahedron* **1992**, *48*, 10399–10422.

(28) Ingold, K. U.; Luszyk, J.; Scaiano, J. C. *J. Am. Chem. Soc.* **1984**, *106*, 343–348.

(29) Rosenstein, I. In *Radicals in Organic Synthesis*; Renaud, P., Sibi, M. P., Eds.; Wiley-VCH: Weinheim, 2001; Vol. 1, pp 50–71.

(30) Curran, D. P.; Liu, H. *J. Chem. Soc., Perkin Trans. 1* **1994**, 1377–1393.

## SCHEME 7

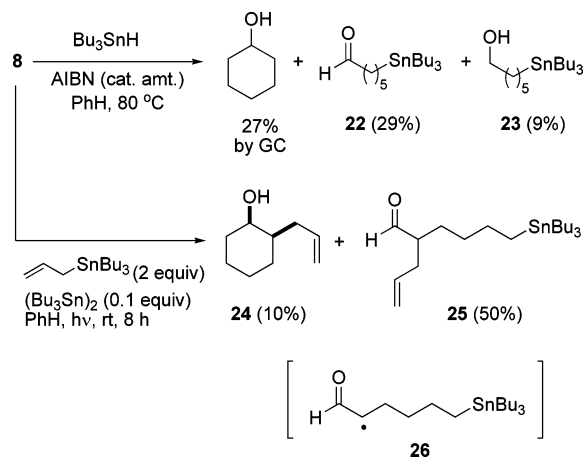

of reaction of radical **2** is the cyclization followed by a 1,3-stannyl shift to give  $\beta$ -stannyloxy radical **4**.

The reaction of bromoaldehyde **8** with tributyltin hydride (Scheme 7) gave 27% of cyclohexanol as determined by gas chromatographic analysis of the reaction mixture using decane as internal standard. The  $^1\text{H}$  NMR spectrum (in  $\text{CDCl}_3$ ) of the crude cyclization mixture exhibits a broad singlet at  $\delta$  3.56 (O–CH of cyclohexanol) overlapped with a triplet at  $\delta$  3.62 (O– $\text{CH}_2$  of alcohol **23**). Intensive chromatographic separation afforded straight reduction product **22** (29%) and over-reduction product **23** (9%). When bromoaldehyde **8** was treated with 2 equiv of allyltributyltin, we isolated 10% of the alcohol **24**<sup>31</sup> and 50% of aldehyde **25**. A small amount of the trans-isomer of alcohol **24**<sup>32</sup> with a characteristic  $^1\text{H}$  NMR signal ( $\text{CDCl}_3$ ) at  $\delta$  3.25 (td,  $J = 9.7, 4.6$  Hz) was also observed in the crude product but not isolated. Aldehyde **25** is apparently derived from the trapping of  $\alpha$ -carbonyl radical **26** by the allylstannane. Radical **26** in turn comes from a 1,5-hydrogen abstraction of the  $\alpha$ -stannyl radical generated from bromoaldehyde **8**.<sup>2c</sup> The lower yield of cyclohexanol for the cyclization of aldehyde **8** and the formation of a large amount of aldehyde **25** in the trapping experiment indicate that the 1,5-hydrogen transfer is a serious competing process of the 1,6-cyclization reaction.

In the 5-hexenyl radical system, the *gem*-dialkyl effect is known to be able to accelerate the cyclization for at least 10-fold.<sup>6a</sup> The *gem*-dimethyl substitution is also often found in many triquinane natural products.<sup>33</sup> Therefore, we prepared xanthate **13** with *gem*-dimethyl substituents at the  $\alpha$  position of the carbonyl group for our radical cyclization study.<sup>34</sup> The reason that we did not employ the corresponding bromide is due to the synthetic difficulties that we had by using the same approach as the synthesis of bromide **1**; the *gem*-dimethyl substituents severely destabilize the dithiane bromide synthetic intermediate, and the overall yield is too low. As shown in Scheme 5, the xanthate synthesis started from the protection of aldehyde **9**<sup>35</sup> with ethylene glycol to afford dioxolane **10** (69%). Ozonolysis of the terminal olefin in **10** followed by a triethyl-

## SCHEME 8

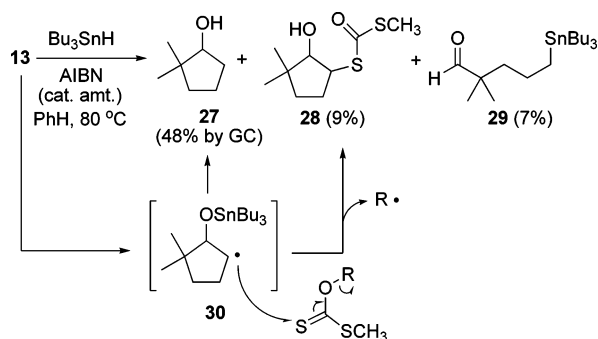

## SCHEME 9

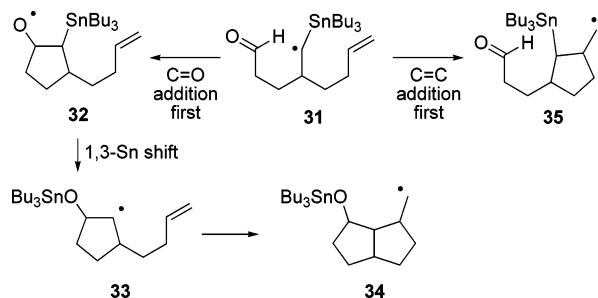

amine workup<sup>36</sup> gave aldehyde **11** in an 80% yield. Note that the use of sodium bicarbonate in the ozonolysis reaction in dichloromethane is essential to ensure a good yield. Aldehyde **11** was then treated with tributyltin lithium,<sup>24</sup> and the resulting alkoxide was trapped with carbon disulfide and methyl iodide in sequence to generate the xanthate **12** (67%). The dioxolane in **12** was then removed under acidic condition in the presence of excess paraformaldehyde in wet THF to afford xanthate aldehyde **13** (90%).

The cyclization of xanthate aldehyde **13** (Scheme 8) gave a 48% GC yield of alcohol **27**,<sup>37</sup> using decane as internal standard, and 7% yield of straight reduction product **29**. In addition, we also isolated dithiocarbonate **28** in 9% yield. This product presumably comes from the addition of the radical intermediate **30** to the sulfur atom of the thiocarbonyl group in xanthate **13** followed by a  $\beta$ -scission of the O–C bond.<sup>34</sup> Comparing this result to the cyclization of bromide **1** (Scheme 6), the cyclization of xanthate **13** was only improved slightly based on the cyclization/reduction product ratio (vide infra).

**Tandem Cyclizations Terminated with an Olefin.** With our initial success in the model studies, we decided to investigate the radical system **31** (Scheme 9). A 1,5-cyclization of radical **31** to the formyl group would produce alkoxy radical **32**. This process would be followed by a 1,3-stannyl shift to afford radical **33**, which could cyclize with the olefin to give the bicyclic radical **34**. However, when radical **31** adds to the olefin first, the process would lead to the monocyclic radical **35**. Taking the ratio of products derived from radicals **34** and **35** would give us useful information about the relative rates of the two cyclizations of radical **31**.

To prepare suitable substrates to generate radical **31**, we started by the reaction of aldehyde **5** with cyclohexylamine (Scheme 10). The resulting imine was then alkylated with

(31) Speziale, V.; Armat, M.; Lattes, A. *Heterocycl. Chem.* **1976**, *13*, 349–3

(32) Hegedus, L. S.; McKearin, J. M. *J. Am. Chem. Soc.* **1982**, *104*, 2444–2451.

(33) Mehta, G.; Srikrishna, A. *Chem. Rev.* **1997**, *97*, 671–719.

(34) Zard, S. Z. *Radicals in Organic Synthesis*; Renaud, P., Sibi, M. P., Eds.; Wiley-VCH: Weinheim, 2001; Vol. 1, pp 90–108.

(35) House, H. O.; Liang, W. C.; Weeks, P. D. *J. Org. Chem.* **1974**, *39*, 3102–3107.

(36) Hon, Y.-S.; Lin, S.-W.; Lu, L.; Chen, Y.-J. *Tetrahedron* **1995**, *51*, 5019–5034.

(37) Kopecky, K. R.; Levine, C. *Can. J. Chem.* **1981**, *59*, 3273–3279.

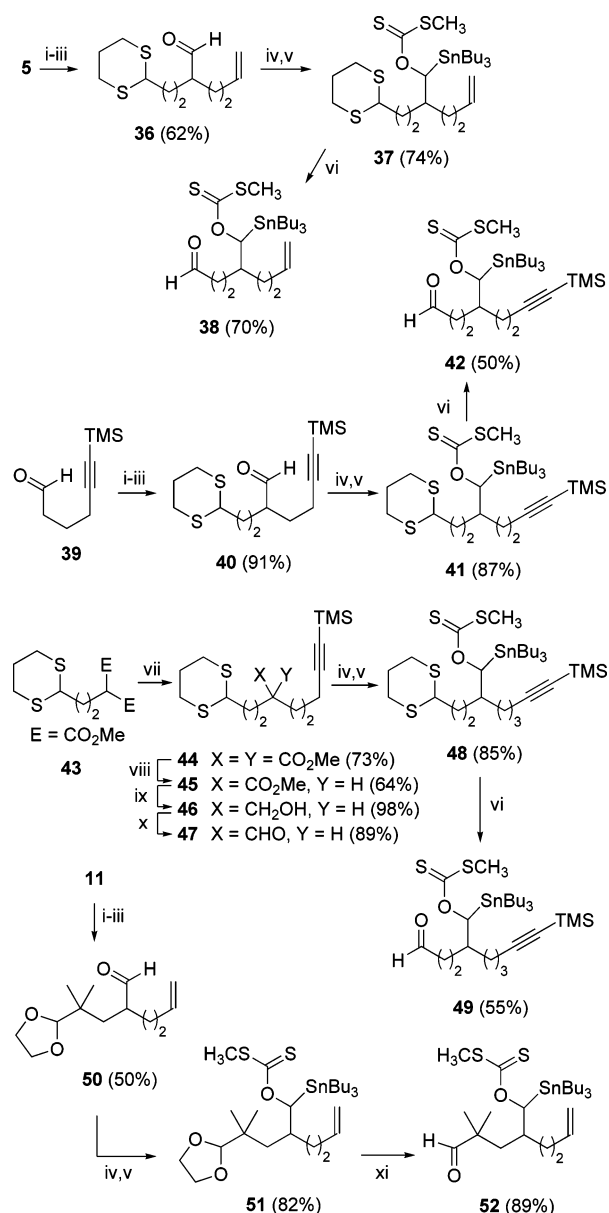
SCHEME 10<sup>a</sup>

<sup>a</sup> Reagents and conditions: (i) cyclohexylamine,  $\text{K}_2\text{CO}_3$ , PhH, rt; (ii) LDA, THF,  $-78^\circ\text{C}$ ,  $\text{Br}(\text{CH}_2)_2\text{CH}=\text{CH}_2$  for **36** and **50**, 2-(2-bromoethyl)-1,3-dithiane for **40**; (iii) 1 N HCl; (iv)  $\text{Bu}_3\text{SnH}$ , LDA, THF,  $-78^\circ\text{C}$ ; (v)  $\text{CS}_2$ ,  $-78^\circ\text{C}$  followed by MeI,  $-78^\circ\text{C}$  to rt; (vi) MeI, acetone/ $\text{H}_2\text{O}$ , reflux; (vii) NaH, DMF followed by  $\text{I}(\text{CH}_2)_3\text{CCTMS}$ ; (viii) NaCN, DMF,  $120^\circ\text{C}$ ; (ix) LAH, THF,  $0^\circ\text{C}$ ; (x) Swern oxid.; (xi) TsOH (1 equiv), HCHO (3 equiv), THF/ $\text{H}_2\text{O}$ ,  $60^\circ\text{C}$ .

4-bromobutene followed by hydrolysis to afford aldehyde **36** (62%). According to the methods described above, we prepared xanthate **38** from aldehyde **36** through xanthate **37**.

As shown in Table 1 (entry 1), slow addition of a benzene solution of tributyltin hydride and a catalytic amount of AIBN to a refluxing benzene solution of **38** gave a total of 33% yield of bicyclic alcohols **53a–c**. In addition to these alcohols, we also isolated aldehyde **55** (33%) and alcohol **56** (5%). These latter two products are derived from direct olefin cyclization of the  $\alpha$ -stannyl radical and appear to be mixtures of stereoisomers, and we did not determine the stereochemistry. Alcohol **56** presumably comes from further reduction of the formyl group in **55** by the excess tributyltin hydride.<sup>28</sup>

TABLE 1. Radical Cyclizations of Xanthate **38** with Tributyltin Hydride (TBTH)

entry	method <sup>a,b</sup>	TBTH (equiv)	product yield (%)					C=O/ C=C
			<b>53a,c</b> <sup>c</sup>	<b>53b</b>	<b>54</b>	<b>55</b>	<b>56</b>	
1	A	1.3	29	4	33	5	0.87	
2	B	1.3	32		5 <sup>d</sup>	51	0.73	
3	B	2.6	34		9 <sup>e</sup>	23	0.80	

<sup>a</sup> Method A: A benzene solution of tributyltin hydride and AIBN (5–15 mol %) was added over 4 h to a refluxing benzene solution of the substrate (0.1 M). The resulting mixture was heated at the same temperature for 2 h. Method B: Tributyltin hydride was added in one portion to a refluxing benzene solution of the substrate and AIBN (15 mol %). The resulting mixture was heated at the same temperature for 4 h. <sup>b</sup> The final concentration relative to the substrate was 0.05 M. <sup>c</sup> **53a/53c** = 85/15. This ratio was extrapolated from the GC ratio of the corresponding benzoates. <sup>d</sup> **54a/54b** = 76/24. <sup>e</sup> **54a/54b** = 87/13.

Bicyclic alcohols **53a–c** are tandem cyclization products derived from radical addition to the carbonyl group first. Alcohol **53b** was isolated in 4% yield. The stereochemistry of **53b** was determined by comparing its benzoate derivative with the spectroscopic data reported by Nagai, Lazor, and Wilcox.<sup>38</sup> The major bicyclic alcohol **53a** was isolated as a mixture with another stereoisomer in a combined yield of 29%. This mixture was converted to the benzoate, and the ratio of the two benzoates determined by gas chromatography is 85/15. The major benzoate was identified by comparison to the reported spectroscopic data; however, the minor isomer does not correspond to any of the three stereoisomers reported by Nagai, Lazor, and Wilcox.<sup>38</sup> We therefore speculate that this benzoate not reported by Nagai et al. might be derived from alcohol **53c** with the hydroxyl and methyl groups at the exo-face.

To probe the reversibility of the carbonyl cyclization step, we performed the reaction by adding tributyltin hydride (1.3 equiv) in one portion to the xanthate **38** in refluxing benzene (entry 2). By mixing tributyltin hydride with the substrate in this fashion, it provides a high local tributyltin hydride concentration so that trapping the radical intermediates could be easier. If the carbonyl cyclization is reversible, we may be able to trap the alkoxy radical **32** and isolate more carbonyl addition products this way.<sup>4f</sup>

As shown in entry 2, we obtained 32% of a bicyclic alcohol mixture of **53a** and **53c**, and 51% of aldehyde **55**. We also isolated 5% of a monocyclic alcohol mixture consisting of **54a**<sup>13i</sup> and **54b** in a ratio of 76/24 (**54a/54b**) as determined by <sup>1</sup>H NMR integration of the olefinic protons. Although the isomers are not separable, the presence of **54b** is apparent by observing a multiplet at  $\delta$  5.32–5.42, typical for a vicinal disubstituted olefin, in the <sup>1</sup>H NMR spectrum ( $\text{CDCl}_3$ ). The cis/trans isomer ratio of these 3-substituted cyclopentanol could not be determined.

(38) Nagai, M.; Lazor, J.; Wilcox, C. S. *J. Org. Chem.* **1990**, *55*, 3440–3442.

The presence of these two monocyclic alcohols indicates that with a higher local concentration of tributyltin hydride we could trap the intermediate  $\beta$ -stannyloxy-substituted radical **33**. The surprising isomerization of the olefin observed in **54** is presumably due to the allylic hydrogen abstraction of the terminal olefin by some unidentified radical species. The ratio of C=O addition products **53** and **54** versus direct C=C addition product **55** is 0.73. By doubling the amount of tributyltin hydride to 2.6 equiv (entry 3), the isolation yield of the monocyclic alcohol mixture of **54** (9%; **54a/54b** = 5/1) almost doubled. We also obtained an appreciable amount of an over-reduction product **56** (31%). Apparently, the trapping of radical **33** becomes more efficient with higher concentration of tributyltin hydride. However, the overall ratio of C=O/C=C addition products ((**53** + **54**)/(**55** + **56**)) is 0.80. This value is not significantly different from that of the reaction with 1.3 equiv of tributyltin hydride (entry 2). In fact, in the two experiments with direct mixing of the substrate with tributyltin hydride (entries 2, 3), the C=O/C=C addition product ratios are slightly lower than that of the experiment with slow addition of tributyltin hydride (entry 1). We believe that these differences are within experimental errors.

As shown in entries 2 and 3 of Table 1, we were not able to trap the alkoxy radical **32** by having high local concentration of tributyltin hydride. This phenomenon indicates that the 1,3-stannyl shift must be so fast that intermolecular trapping of the alkoxy radical by high concentration of tributyltin hydride is not possible. In addition, although  $\beta$ -stannyloxy radical **33** can be trapped, the more efficient trapping of this radical does not significantly increase the ratio of C=O/C=C addition products. The cyclization of radical **31** with the olefin to give radical **35** belongs to the 5-hexenyl radical cyclization system and is presumably an irreversible process.<sup>39</sup> Therefore, the 1,3-stannyl shift is more likely an irreversible process.

These results also reveal that the apparent rate of formation of  $\beta$ -stannyloxy radical **33** is similar to the rate of 5-*exo* cyclization of  $\alpha$ -stannyl radical with the olefin. Therefore, either by choosing a slower olefin cyclization system or by finding ways to accelerate the carbonyl addition rate may direct the reaction to the tandem cyclization pathway.

The stereoselectivity of the tandem cyclization products **53** can be explained by adopting a pseudo-chair transition state **31A** with all of the substituents at the equatorial position as shown in Scheme 11.<sup>40,41</sup> This approach constructs the 1,3-*trans* relationship in alkoxy radical **32A**. The oxy radical and the tributylstannyl group have a *cis*-relationship; therefore, a facile stannyl shift occurs to give radical *trans*-**33**. Further cyclization of *trans*-**33** proceeds with a well-known endo-selectivity<sup>41</sup> and gives the major isomer **53a** and the minor isomer **53c**.

The other isomer **53b** presumably comes from the pseudo-chair transition state **31B** in which the butenyl group occupies the axial position. The cyclization of **31B** gives alkoxy radical **32B** with a 1,3-*cis* relationship of the substituents. 1,3-Stannyl shift of **32B** gives radical *cis*-**33** that cyclizes to afford bicyclic alcohol **53b**. It is interesting to find that with a high local concentration of tributyltin hydride, bicyclic alcohol **53b** was not found (entries 3, 4). This is an indication that the cyclization

## SCHEME 11

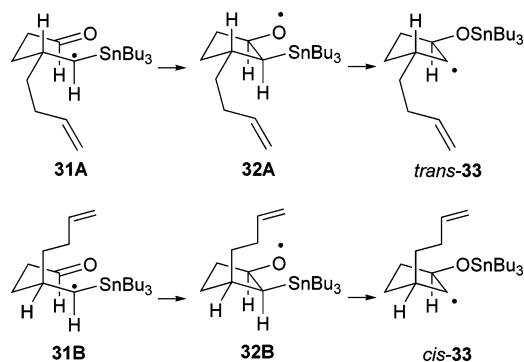

## SCHEME 12

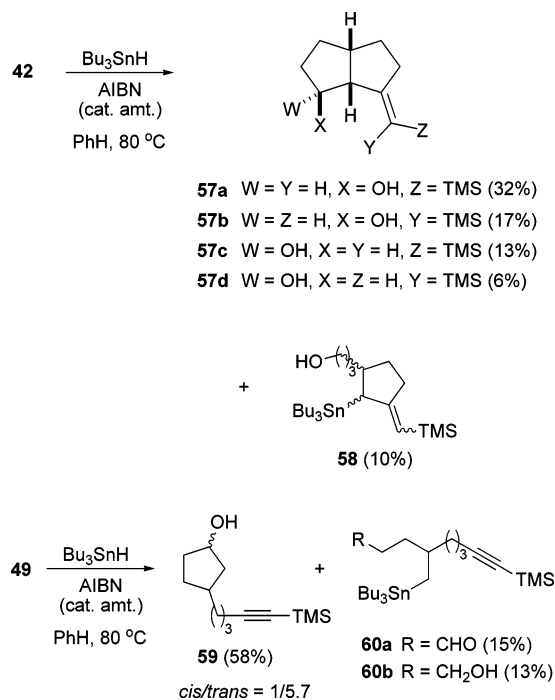

of radical *cis*-**33** is slower due to the steric effect. The steric effect also explains the *exo*-selectivity for the cyclization of *cis*-**33**.

**Tandem Cyclizations Terminated with a Triple Bond.** As mentioned above, to increase the extent of tandem cyclizations, we need a slower cyclization system such that the cyclization of the carbonyl group can outmatch. It is known that 5-hexynyl radical undergoes 5-*exo* cyclization with a slower rate than 5-hexenyl radical.<sup>39</sup> We therefore synthesized alkyne xanthate **42** from aldehyde **39**<sup>42</sup> (Scheme 10) using methodology similar to that of the preparation of xanthates **38**.

The cyclization of xanthate **42** with tributyltin hydride (Scheme 12) gave bicyclic alcohols **57a** (32%), **57b** (17%), **57c** (13%), and **57d** (6%) in addition to 10% of monocyclic alcohol **58**. The bicyclic alcohols **57** are tandem cyclization products, and the monocyclic alcohol **58** comes from direct addition of the  $\alpha$ -stannyl radical to the triple bond. Indeed, the ratio of **57/58** is increased to 6.8 by comparison to the cyclization of xanthate **38**.

(41) Curran, D. P.; Porter, N. A.; Giese, B. *Stereochemistry of radical Reactions*; VCH: Weinheim, 1996; Chapter 2, pp 23–115.

(42) Louw, J. van der; Baan, J. L. van der; Kanter, F. J. J. de; Bickelhaupt, F.; Klumpp, G. W. *Tetrahedron* **1992**, *48*, 6087–6104.

(39) Beckwith, A. L. J. *Tetrahedron* **1981**, *37*, 3073–3100.

(40) (a) Beckwith, A. L. J.; Schiesser, C. H. *Tetrahedron Lett.* **1985**, *26*, 373–376. (b) Beckwith, A. L. J.; Schiesser, C. H. *Tetrahedron* **1985**, *41*, 3925–3941. (c) Spellmeyer, D. C.; Houk, K. N. *J. Org. Chem.* **1987**, *52*, 959–974. For a review, see: Schiesser, C. H.; Skidmore, M. A. In *Radicals in Organic Synthesis*; Renaud, P., Sibi, M. P., Eds.; Wiley-VCH: Weinheim, 2001; Vol. 1, pp 337–359.

TABLE 2. Radical Cyclizations of Xanthate 52

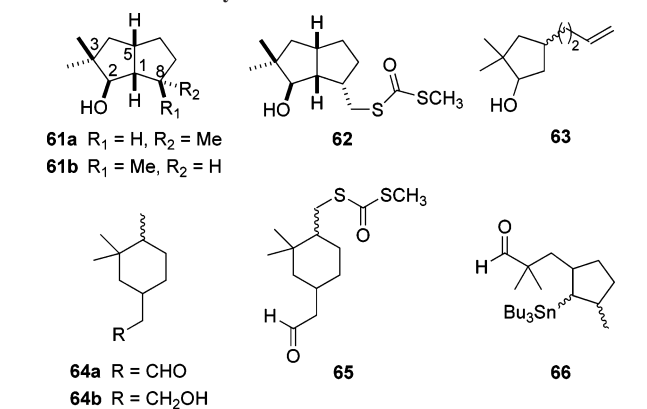

entry	method <sup>a</sup>	TBTH (equiv)	product yield (%)						C=O/ C=C
			61	62	63	64a <sup>c</sup>	64b	65	
1	A <sup>b</sup>	1.3	41 <sup>d</sup>	5	21		5	13	
2	B <sup>b</sup>	1.3	32 <sup>d</sup>	11	20	4	5	13	
3	B <sup>b</sup>	5.2	31 <sup>d</sup>	14	9	16	5	14	
4	C		17 <sup>e</sup>	16				14	

<sup>a</sup> Methods A and B: Same as in Table 1. Method C: A benzene solution (0.05 M) of xanthate **52** was mixed with 4 equiv of triethylborane (1 M in hexane) and then purged with dry air (75 mL/mol of **52**). The reaction mixture was stirred at rt for 4 h. <sup>b</sup> The final concentration relative to **52** was 0.05 M. <sup>c</sup> Aldehydes **64a** and **66** were not separable by SiO<sub>2</sub> column chromatography, and the yields were based on <sup>1</sup>H NMR integrations. For the purpose of identification, an authentic sample of **64a** was obtained by oxidation of alcohol **64b**. <sup>d</sup> **61a/61b** = 8/1. <sup>e</sup> Only **61a**.

The stereochemical relationships of the four isomeric alcohols **57** were determined by NOE experiments and <sup>13</sup>C NMR spectroscopy.<sup>43</sup> The monocyclic alcohol **58** is a mixture of several stereoisomers, and we did not determine their structures rigorously.

As shown in Scheme 10, we also prepared xanthate **49** from malonate **43**.<sup>13i</sup> Alkylation of **43** with 5-iodo-1-trimethylsilyl-1-pentyne<sup>44</sup> gave malonate **44** (73%). Heating of **44** with sodium cyanide in DMF yielded the monoester **45** (64%).<sup>45</sup> The ester was reduced with LAH to give alcohol **46** (98%) and then oxidized via Swern oxidation to afford aldehyde **47** (89%).<sup>46</sup> The conversion of aldehyde **47** to xanthate **49** was accomplished according to the same protocol described above.

With an even slower 6-heptynyl radical cyclization system<sup>39</sup> present in xanthate **49**, the cyclization of **49** (Scheme 12) gave only monocyclic alcohol **59** in 58% yield as a mixture of cis/trans isomers (1/5.7). We also isolated 15% of uncyclized reduction product **60a** and the over-reduction product alcohol **60b** (13%).

**Tandem Cyclizations with gem-Dimethyl Substituents.** As mentioned earlier, for the cyclization of xanthate **13**, the acceleration effect of the geminal dimethyl groups at the  $\alpha$ -position of the carbonyl is only modest. To examine this system more closely, we also synthesized xanthate **52** (Scheme 10) from aldehyde **11** using the same approach described above.

The radical cyclization studies of **52** are shown in Table 2. Under the condition of slow addition of tributyltin hydride (1.3

SCHEME 13

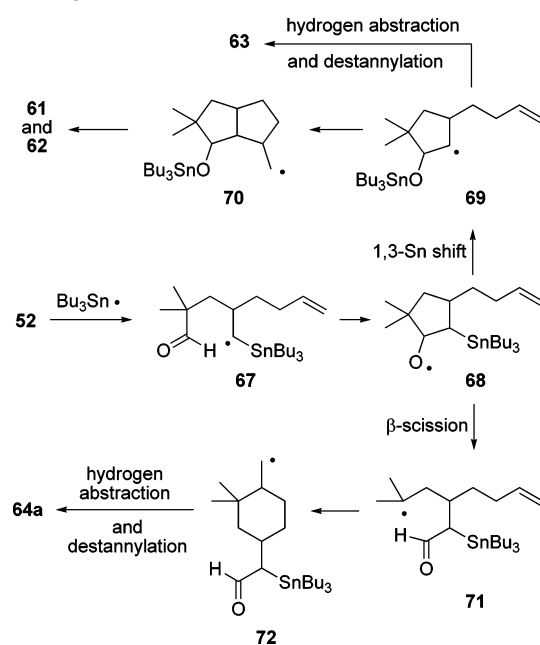

equiv) to **52** (entry 1), we isolated bicyclic alcohols **61** (41%) and **62** (5%). Alcohol **62** comes from the bicyclic radical **70** (Scheme 13) through addition of **70** to the sulfur atom of the thiocarbonyl moiety of xanthates.

The bicyclic alcohol **61** is an 8/1 mixture of two isomers. The major isomer **61a** was separated by silica gel column chromatography. However, a pure sample of the minor isomer **61b** could only be obtained through preparative gas chromatography. The stereochemical assignments of the bicyclic alcohols **61a,b** are based on the NOESY experiments. This stereochemical result is also in accord with the prediction based on the transition state model shown in Scheme 11. By analogy, we assume that bicyclic alcohol **62** has the same stereochemistry as the major alcohol isomer **61a**. This is supported by observing the same <sup>13</sup>C NMR chemical shifts (in CDCl<sub>3</sub>) of C(2) at  $\delta$  80.7 for these two compounds.

Interestingly, we also obtained 21% of aldehyde **64a** contaminated with 5% of aldehyde **66** derived from direct cyclization of  $\alpha$ -stannyl radical **67** (Scheme 13) to the olefin. Cyclization of radical **67** to the carbonyl group generates alkoxy radical **68**. The formation of **64a** indicates that the alkoxy radical **68** not only undergoes 1,3-stannyl shift to give  $\beta$ -stannyl radical **69** but also proceeds through a  $\beta$ -scission<sup>47</sup> to give the tertiary radical **71**. The formation of a tertiary radical apparently facilitates the  $\beta$ -scission process. This tertiary radical cyclizes further to the olefin and affords radical **72**. The  $\alpha$ -stannyl aldehyde moiety is known to equilibrate with the corresponding tin enolate and destannylates easily;<sup>48,49</sup> therefore, radical **72** eventually leads to the final product aldehyde **64a**. The combined yields of **61**, **62**, and **64a** are 67% and reflect the fraction of carbonyl cyclization of radical **67**. This value (67%)

(43) Whitesell, J. K.; Matthews, R. S. *J. Org. Chem.* **1977**, *42*, 3878–3882.

(44) Mukai, C.; Nomura, I.; Kitagaki, S. *J. Org. Chem.* **2003**, *68*, 1376–1385.

(45) McMurry, J. E. *Org. React.* **1976**, *24*, 187–224.

(46) (a) Mancuso, A. J.; Huang, S. L.; Swern, D. *J. Org. Chem.* **1978**, *43*, 2480–2482. (b) Mancuso, A. J.; Swern, D. *Synthesis* **1981**, 165–185.

(47) For reviews, see: (a) Suárez, E. In *Radicals in Organic Synthesis*; Renaud, P., Sibi, M. P., Eds.; Wiley-VCH: Weinheim, 2001; Vol. 2, pp 440–454. (b) Hartung, J.; Gottwald, T.; Spehar, K. *Synthesis* **2002**, 1469–1498.

(48) Pereyre, M.; Quintard, J.-P.; Rahm, A. *Tin in Organic Synthesis*; Butterworth: London, 1987; Chapter 12, p 286.

(49) Dang, H.-S.; Roberts, B. P. *J. Chem. Soc., Perkin Trans. 1* **1996**, 769–775.

divided by the yield of aldehyde **66** (5%) gives a C=O/C=C addition products ratio of 13. As compared to the cyclization of xanthate **38** (Table 1), the extent of carbonyl addition of xanthate **52** has increased appreciably. However, although the *gem*-dimethyl substituents at the  $\alpha$ -position of the carbonyl group can accelerate the carbonyl cyclization, due to the competing  $\beta$ -scission, this structural modification does not help us to obtain more bicyclic alcohols.

Recall that the cyclization of xanthate **13** gives alcohol products **27** and **28** with combined yields of only 57% (Scheme 8). Re-examining this cyclization, we prepared an authentic sample of 5-methylhexanal<sup>50</sup> and found the presence of this aldehyde in the crude product. 5-Methylhexanal is the product derived from  $\beta$ -scission of the cyclized alkoxy radical. Direct analysis of the reaction aliquot by GC and <sup>1</sup>H NMR analysis of the crude product all indicate that the ratio of alcohol **27** relative to 5-methylhexanal is about 3/1.

We also carried out the reaction by stirring a benzene solution of xanthate **52** with 4 equiv of triethylborane in the presence of air<sup>51</sup> at room temperature, hoping to perform a group transfer type of cyclization (Table 2, entry 4). Ethyl radical generated from this initiation method could add to the sulfur atom of the carbonyl group in xanthate **52** and subsequently release  $\alpha$ -stannyl radical **67**. Indeed, we were able to isolate 16% of alcohol **62**; however, surprisingly we still obtained 17% of alcohol **61**.<sup>52</sup> In this experiment, we also isolated 14% of aldehyde **65** derived from radical **72**. This aldehyde is a 5/1 mixture of two isomers, and we did not determine the stereochemistry. Aldehyde **66** is eliminated under this condition. This is because triethylborane is known to be able to promote radical cyclizations of carbonyl compounds.<sup>8</sup> The ratio of (**61** + **62**)/**65** = 2.4 represents the partition between 1,3-tin transfer and  $\beta$ -scission, respectively, and is about the same as the reaction carried out with tributyltin hydride at 80 °C (entry 1; (**61** + **62**)/**64a** = 2.2).

To study the effect of the concentration of tributyltin hydride, we performed the reaction by directly mixing xanthate **52** with tributyltin hydride and heating at 80 °C in benzene (entries 2, 3). This method using 1.3 equiv of tributyltin hydride (entry 2) gave 32% of an alcohol mixture of **61a** and **61b** (**61a**/**61b** = 8/1). Under this condition, we could isolate 11% of monocyclic alcohol **63** derived from trapping of the  $\beta$ -tributylstannyloxy-substituted radical **69** by tributyltin hydride. Interestingly, alcohol **63** is approximately a 1/1 mixture of *cis* and *trans* isomers. Presumably, the *cis* radical **69** cyclizes slower than the *trans* isomer and is trapped easier by tributyltin hydride, whereas most of the *trans* radical **69** cyclizes to give the tandem cyclization products **61**. The aldehyde **64a** was obtained in 20% in addition to 5% of aldehyde **66**. Because of the more efficient trapping of radicals **70** and **72** by the higher local concentration of tributyltin hydride in this reaction condition, the dithiocarbonates **62** and **65** were not formed; however, further reduction of aldehyde **64a** by tributyltin hydride occurred and gave 4% of alcohol **64b**.

When we used a large excess of tributyltin hydride (5.2 equiv; entry 3), the monocyclic alcohol **63** slightly increased to 14%. The yield of over-reduction product **64b** also increased (16%) with diminished amount of aldehyde **64a** (9%). Once again,

the overall ratios of the C=O/C=C addition products stay at similar values for the three experiments in entries 1–3, and we are not able to trap the intermediate alkoxy radical **68** by tributyltin hydride. The ratio of products derived from 1,3-stannyl shift of alkoxy radical **68** relative to the products from  $\beta$ -scission of **68** remains at an approximately constant value of 2. The trapping of  $\beta$ -stannyloxy radical **69** under high local concentration of tributyltin hydride does not significantly change the C=O/C=C addition products ratios nor the partitions between 1,3-stannyl shift and  $\beta$ -scission of alkoxy radical **68**. Therefore, it is likely that 1,3-stannyl shift and  $\beta$ -scission of radical **68** are irreversible processes. The 6-*exo* cyclization of radical **71** must be very fast because we could not find the product from direct trapping of this tertiary radical by tributyltin hydride.

## Summary

In summary, intramolecular cyclization of  $\alpha$ -tributylstannyl radical with formyl group proceeds quite successfully for five-membered ring formation. The intermediate  $\beta$ -tributylstannyl alkoxy radical undergoes a facile 1,3-stannyl shift and generates a  $\beta$ -tributylstannyloxy-substituted carbon radical. This 1,3-stannyl shift is likely to be irreversible and drives the cyclization to completion. This special feature allows us to construct tandem cyclization systems to afford the bicyclo[3.3.0]octan-2-ol skeleton. *gem*-Dimethyl substituents carried at the  $\alpha$ -position of the formyl group can enhance the cyclization rate; however,  $\beta$ -scission of the cyclized alkoxy radical giving a tertiary radical becomes a serious competing process.

## Experimental Section

**General.** For details, see the Supporting Information.

**5-Bromo-5-(tributylstannyl)pentanal (1).** To a solution of 0.46 mL (3.3 mmol) of diisopropylamine in 3 mL of dry THF cooled in an ice–water bath was added dropwise 2.2 mL (3.3 mmol) of a 1.5 M solution of butyllithium in hexane. The reaction mixture was stirred at the same temperature for 10 min followed by the addition of 0.89 mL (3.3 mmol) of tributyltin hydride over 10 min. The resulting solution was stirred at 0 °C for another 30 min and then cooled in a dry ice–acetone bath. To this cooled solution was added over a period of 1 h a solution of 567 mg (2.98 mmol) of aldehyde **5** in 3 mL of dry THF. The resulting mixture was stirred at the same temperature for 1 h and then poured into a mixture of ether (100 mL) and saturated ammonium chloride solution (50 mL). The organic layer was washed with brine (50 mL), dried (MgSO<sub>4</sub>), and concentrated in vacuo. To a solution of the residue and 2.0 g (6.0 mmol) of carbon tetrabromide in 6 mL of dichloromethane cooled in an ice–water bath was added dropwise a solution of 1.6 g (6.0 mmol) of triphenylphosphine in 6 mL of dichloromethane. The reaction mixture was stirred at room temperature for another 1 h, poured into 20 mL of a mixture of hexane/ethyl acetate (9/1), filtered through a short silica gel column, and then concentrated in vacuo. The residue was mixed with 108 mg of sodium bicarbonate, 130 mg of Celite, 3 mL of dichloromethane, and 2 mL of acetonitrile, and then cooled at –15 °C. To this cooled mixture was added over 10 min a solution of 4.93 g (9.0 mmol) of ceric ammonium nitrate in 25 mL of acetonitrile/water (9/1). The resulting mixture was stirred at the same temperature for another 10 min, filtered, and the filtrate was partitioned between ether (100 mL) and water (50 mL). The organic layer was washed with brine (50 mL), dried (MgSO<sub>4</sub>), and concentrated in vacuo. The residue was chromatographed over silica gel (eluted with hexane/ethyl acetate, 98/2) to give 762 mg (56%) of **1** as a pale yellow oil: IR (neat) 1718 cm<sup>-1</sup>; <sup>1</sup>H NMR (200 MHz)  $\delta$  0.80–1.17 (m, 15H), 1.18–

(50) Oscarsson, K.; Poliakov, A.; Oscarson, S.; Danielson, U. H.; Hallberg, A.; Samuelsson, B. *Bioorg. Med. Chem.* **2003**, *11*, 2955–2964.

(51) Yorimitsu, H.; Oshima, K. In *Radicals in Organic Synthesis*; Renaud, P., Sibi, M. P., Eds.; Wiley-VCH: Weinheim, 2001; Vol. 1, pp 11–27.

(52) Spiegel, D. A.; Wiberg, K. B.; Schacherer, L. N.; Medeiros, M. R.; Wood, J. L. *J. Am. Chem. Soc.* **2005**, *127*, 12513–12515.



1.82 (m, 14H), 1.82–2.12 (m, 2H), 2.32–2.56 (m, 2H), 3.58 (dd,  $J = 8.3, 5.5$  Hz, 1H), 9.74 (br s, 1H);  $^{13}\text{C}$  NMR (75 MHz)  $\delta$  9.9 ( $J_{\text{C-Sn}} = 310$  Hz), 13.6, 22.4, 27.3 ( $J_{\text{C-Sn}} = 60$  Hz), 28.9 ( $J_{\text{C-Sn}} = 20$  Hz), 36.8, 38.6, 42.8, 202.0. Anal. Calcd for  $\text{C}_{17}\text{H}_{35}\text{BrOSn}$ : C, 44.97; H, 7.77. Found: C, 45.37; H, 8.11.

**4-(2,6-Dithiaclohexyl)butanal (5).** A 50% glutaric dialdehyde aqueous solution (27 mL, 149 mmol) was extracted with chloroform (25 mL  $\times$  3). To the combined chloroform extracts was added 3.10 mL of 1,3-propanedithiol (30.9 mmol). The resulting solution was cooled in an ice–water bath followed by the addition of 1.30 mL (10.3 mmol) of boron trifluoride diethyl etherate over a period of 2 min. The reaction mixture was then stirred at 60–70 °C for 5 h and then washed with water (100 mL  $\times$  3). The organic layer was dried ( $\text{MgSO}_4$ ) and concentrated in vacuo. The residual oil was chromatographed over silica gel (eluted with hexane/ethyl acetate, 9/1) to give 4.77 g (81%) of **5** as a pale yellow oil: IR (neat) 1713  $\text{cm}^{-1}$ ;  $^1\text{H}$  NMR ( $\text{CDCl}_3$ , 200 MHz)  $\delta$  1.55–1.85 (m, 5H), 1.86–2.07 (m, 1H), 2.34 (t,  $J = 7.0$  Hz, 2H), 2.60–2.88 (m, 4H), 3.90 (t,  $J = 7.0$  Hz, 2H), 9.62 (t,  $J = 1.5$  Hz, 1H);  $^{13}\text{C}$  NMR ( $\text{CDCl}_3$ , 75 MHz)  $\delta$  18.9, 25.5, 29.9, 34.3, 42.8, 47.6, 201.4; HRMS calcd for  $\text{C}_8\text{H}_{14}\text{S}_2\text{O}$   $m/z$  190.0643, found 190.0644.

**5-(2,6-Dithiaclohexyl)pentanal (7).** A mixture of 2.31 g (9.31 mmol) of 1,3-dioxolane **6**,<sup>27</sup> 17 mg (0.09 mmol) of *p*-toluenesulfonic acid monohydrate, 10 mL of THF, and 5 mL of water was stirred at 65–70 °C overnight and then carefully poured into 50 mL of a saturated sodium carbonate solution. The resulting mixture was extracted with dichloromethane (75 mL  $\times$  2). The combined organic layers were dried ( $\text{MgSO}_4$ ) and concentrated in vacuo. The residue was chromatographed over silica gel (eluted with hexane/ethyl acetate, 9/1) to give 1.6 g (84%) of **7** as a pale yellow oil: IR (neat) 1713  $\text{cm}^{-1}$ ;  $^1\text{H}$  NMR ( $\text{CDCl}_3$ , 200 MHz)  $\delta$  1.41–1.95 (m, 7H), 2.00–2.20 (m, 1H), 2.41 (td,  $J = 8.6, 1.5$  Hz, 2H), 2.65–2.95 (m, 4H), 4.00 (t,  $J = 6.9$  Hz, 2H), 9.72 (t,  $J = 1.5$  Hz, 1H);  $^{13}\text{C}$  NMR ( $\text{CDCl}_3$ , 50 MHz)  $\delta$  21.6, 25.9, 26.1, 30.4, 35.1, 43.5, 47.2, 202.1. Anal. Calcd for  $\text{C}_9\text{H}_{16}\text{OS}_2$ : C, 52.91; H, 7.83. Found: C, 52.65; H, 7.87.

**2-(1,1-Dimethyl-4-pentenyl)-1,3-dioxolane (10).** A mixture of 2.32 g (18.4 mmol) of aldehyde **9**,<sup>35</sup> 1.54 mL (27.6 mmol) of ethylene glycol, 0.32 g (1.68 mmol) of *p*-toluenesulfonic acid monohydrate, and 29 mL of benzene was heated under reflux for 4 h using a Dean–Stark apparatus to trap the water. The resulting mixture was partitioned between 100 mL of ether and 50 mL of a 1 N sodium hydroxide solution. The organic layer was washed in sequence with water (50 mL) and brine (50 mL), dried ( $\text{MgSO}_4$ ), and concentrated in vacuo. The residue was chromatographed over silica gel (eluted with hexane/ethyl acetate, 95/5) to give 2.17 g (69%) of **10** as a pale yellow liquid: IR (neat) 1643  $\text{cm}^{-1}$ ;  $^1\text{H}$  NMR ( $\text{CDCl}_3$ , 400 MHz)  $\delta$  0.88 (s, 6H), 1.33–1.42 (m, 2H), 2.04 (dt,  $J = 10.7, 6.5, 1.4$  Hz, 2H), 3.78–3.94 (m, 4H), 4.53 (s, 1H), 4.89 (ddt,  $J = 10.2, 2.0, 1.4$  Hz, 1H), 4.98 (dq,  $J = 17.1, 1.4$  Hz, 1H), 5.72–5.87 (ddt,  $J = 17.1, 10.2, 6.5$  Hz, 1H);  $^{13}\text{C}$  NMR ( $\text{CDCl}_3$ , 100 MHz)  $\delta$  21.4 (q), 28.1 (t), 36.8 (t), 37.0 (s), 65.2 (t), 109.9 (d), 113.9 (t), 139.6 (d); HRMS calcd for  $\text{C}_{10}\text{H}_{18}\text{O}_2$   $m/z$  170.1307, found 170.1297.

**4-Methyl-4-(2,5-dioxolanyl)pentanal (11).** A stream of ozone gas was passed into a mixture of 1.05 mL (5.90 mmol) of olefin **10** and 3.50 g (41.3 mmol) of sodium bicarbonate in 30 mL of dichloromethane cooled in a dry ice–acetone bath. After 20 min, the reaction mixture was purged with nitrogen for another 20 min at the same temperature followed by the addition of 1.60 mL (11.8 mmol) of triethylamine in one portion. The resulting mixture was slowly warmed to room temperature over a period of 2 h and then partitioned between 100 mL of ether and 50 mL of water. The organic layer was washed in sequence with water (50 mL) and brine (50 mL), dried ( $\text{MgSO}_4$ ), and concentrated in vacuo. The residue was chromatographed over silica gel (eluted with hexane/ethyl acetate, 8/2) to give 0.82 g (80%) of **11** as a colorless liquid: IR (neat) 1727  $\text{cm}^{-1}$ ;  $^1\text{H}$  NMR ( $\text{CDCl}_3$ , 400 MHz)  $\delta$  0.89 (s, 6H), 1.59–1.69 (m, 2H), 2.40–2.50 (m, 2H), 3.78–3.93 (m, 4H), 4.50

(t,  $J = 1.8$  Hz, 1H), 9.74 (t,  $J = 2.0$  Hz, 1H);  $^{13}\text{C}$  NMR ( $\text{CDCl}_3$ , 100 MHz)  $\delta$  21.7 (q), 29.3 (t), 36.6 (s), 39.1 (t), 65.2 (t), 109.6 (d), 202.9 (d); HRMS calcd for  $\text{C}_9\text{H}_{15}\text{O}_3$  ( $M - \text{H}$ )  $m/z$  171.1021, found 171.1039.

**O-[1-Tributylstannanyl-4-methyl-4-(2,5-dioxolanyl)]pentyl S-Methyl Dithiocarbonate (12).** To a solution of 2.70 mL (19.5 mmol) of diisopropylamine in 18 mL of dry THF cooled in an ice–water bath was added over 15 min 12.2 mL (19.5 mmol) of a 1.6 M solution of butyllithium in hexane. The reaction mixture was stirred at the same temperature for 15 min followed by the addition of 5.20 mL (19.5 mmol) of tributyltin hydride over 5 min. The resulting solution was stirred at 0 °C for another 30 min and then cooled in a dry ice–acetone bath. To this cooled solution was added over a period of 30 min a solution of 3.04 g (17.7 mmol) of aldehyde **11** in 18 mL of dry THF. The resulting mixture was stirred at the same temperature for 1.5 h followed by the addition of 1.2 mL (19.5 mmol) of carbon disulfide over 1 min and then slowly warmed to room temperature over 1.5 h. The reaction mixture was cooled again to –78 °C followed by the addition of 1.65 mL (26.6 mmol) of methyl iodide over 1 min and then stirred for another 45 min. The cold bath was removed, and the resulting mixture was stirred for 45 min at room temperature and then partitioned between 300 mL of ether and 100 mL of water. The organic layer was washed in sequence with water (100 mL) and brine (100 mL), dried ( $\text{MgSO}_4$ ), and concentrated in vacuo. The residue was chromatographed over silica gel (eluted with hexane/ethyl acetate, 95/5) to give 6.55 g (67%) of **12** as a yellow oil:  $^1\text{H}$  NMR ( $\text{CDCl}_3$ , 400 MHz)  $\delta$  0.79–0.99 (m overlapped with a t at 0.87,  $J = 7.3$  Hz, and a s at 0.89, 21H), 1.20–1.36 (m overlapped with a sextet at 1.28,  $J = 7.3$  Hz, 7H), 1.36–1.54 (m, 7H), 1.86–1.95 (m, 1H), 2.01–2.12 (m, 1H), 2.51 (s, 3H), 3.78–3.93 (m, 4H), 4.51 (s, 1H), 5.70 (dd,  $J = 8.9, 5.6$  Hz, 1H);  $^{13}\text{C}$  NMR ( $\text{CDCl}_3$ , 100 MHz)  $\delta$  10.3 (t), 13.7 (q), 18.6 (q), 21.5 (q), 21.7 (q), 27.4 (t), 28.6 (t), 29.0 (t), 35.2 (t), 36.9 (s), 65.2 (t), 85.5 (d), 109.8 (d), 213.4 (s). Anal. Calcd for  $\text{C}_{23}\text{H}_{46}\text{O}_3\text{S}_2\text{Sn}$ : C, 49.91; H, 8.38. Found: C, 49.70; H, 8.31.

**O-[(1-Tributylstannyl-4,4-dimethyl-5-oxo-pentyl) S-Methyl Dithiocarbonate (13).** A mixture of 1.00 g (1.80 mmol) of acetal **12**, 0.160 g (5.40 mmol) of paraformaldehyde, and 0.310 g (1.63 mmol) of *p*-toluenesulfonic acid monohydrate in 9 mL of THF/ $\text{H}_2\text{O}$  (4/1) was heated at 60 °C overnight and then partitioned between ether (100 mL) and a 0.5 M solution of sodium hydroxide (50 mL). The organic layer was washed in sequence with water (50 mL) and brine (50 mL), dried ( $\text{MgSO}_4$ ), and concentrated in vacuo. The residue was chromatographed over silica gel (eluted with hexane/ethyl acetate, 95/5) to give 0.83 g (90%) of **13** as a yellow oil: IR (neat) 1731  $\text{cm}^{-1}$ ;  $^1\text{H}$  NMR ( $\text{CDCl}_3$ , 400 MHz)  $\delta$  0.77–0.99 (m overlapped with a t at 0.87,  $J = 7.3$  Hz, 15H), 1.05 (s, 6H), 1.28 (sextet,  $J = 7.3$  Hz, 6H), 1.37–1.51 (m, 7H), 1.61 (td,  $J = 13.5, 4.5$  Hz, 1H), 1.77 (tt,  $J = 12.2, 4.5$  Hz, 1H), 1.98 (m, 1H), 2.52 (s, 3H), 5.71 (dd,  $J = 9.7, 4.5$  Hz, 1H), 9.43 (s, 1H);  $^{13}\text{C}$  NMR ( $\text{CDCl}_3$ , 100 MHz)  $\delta$  10.3 (t,  $J_{\text{C-Sn}} = 321.2, 307.4$  Hz), 13.6 (q), 18.8 (q), 21.3 (q), 27.4 (t,  $J_{\text{C-Sn}} = 56.8$  Hz), 29.0 (t,  $J_{\text{C-Sn}} = 20.0$  Hz), 35.2 (t), 45.6 (s), 84.4 (d), 205.7 (d), 213.8 (s). Anal. Calcd for  $\text{C}_{21}\text{H}_{42}\text{O}_2\text{S}_2\text{Sn}$ : C, 49.51; H, 8.31. Found: C, 49.20; H, 8.13.

**Radical Cyclization of Bromide 1 Followed by Benzoylation: 5-(Tributylstannyl)pentanal (16).** To a solution of 342 mg (0.75 mmol) of bromide **1** in 3 mL of benzene heated at 80 °C was added over 4 h a solution of 0.24 mL (0.9 mmol) of tributyltin hydride and 6 mg (0.04 mmol) of AIBN in 4.5 mL of benzene. The reaction mixture was stirred for another 1 h followed by the addition of 0.44 mL (3.75 mmol) of benzoyl chloride, 0.43 mL (3.0 mmol) of triethylamine, and 0.75 mL (0.75 mmol) of a 1 N tetrabutylammonium fluoride solution in THF. The resulting mixture was stirred under reflux for 12 h and then partitioned between ether (100 mL) and saturated ammonium chloride solution (100 mL). The organic layer was washed with brine (50 mL), dried ( $\text{MgSO}_4$ ), and concentrated in vacuo. To the residue was added a few drops

of triethylamine, and then it was chromatographed over silica gel (eluted with hexane/ethyl acetate) to give 84 mg (57%) of cyclopentyl benzoate (**15**) and 41 mg (12%) of **16** as a colorless liquid: IR (neat) 1718  $\text{cm}^{-1}$ ;  $^1\text{H}$  NMR (300 MHz)  $\delta$  0.65–1.00 (m, 17H), 1.20–1.75 (m, 16H), 2.41 (td,  $J = 7.2, 1.9$  Hz, 2H), 9.74 (t,  $J = 1.9$  Hz, 1H);  $^{13}\text{C}$  NMR (75 MHz)  $\delta$  8.5 (t;  $J_{\text{C-Sn}} = 310$  Hz), 8.7 (t;  $J_{\text{C-Sn}} = 310$  Hz), 13.6 (q), 26.8 (t), 27.4 (t;  $J_{\text{C-Sn}} = 60$  Hz), 28.2 (t), 29.2 (t;  $J_{\text{C-Sn}} = 20$  Hz), 43.5 (t), 202.9 (d); HRMS calcd for  $\text{C}_{17}\text{H}_{35}\text{O}^{118}\text{Sn}$  ( $\text{M}^+ - \text{H}$ )  $m/z$  373.1704, found  $m/z$  373.1706.

**The Reaction of Bromide 1 with Allyltributyltin: 8-Tributylstannyl-1-octen-4-one (20).** A solution of 290 mg (0.64 mmol) of bromide **1**, 0.803 mL (2.62 mmol) of allyltributyltin, and 65  $\mu\text{L}$  (0.13 mmol) of hexabutyliditin in 1.2 mL of benzene was irradiated under argon for 12 h with 3500 Å lamps. The resulting solution was concentrated in vacuo. The residue was chromatographed over silica gel (eluted in gradient with hexane/ethyl acetate) several times to obtain 29 mg (36%) of *trans*-2-(2-propenyl)cyclopentanol (**19**)<sup>30</sup> and 6.8 mg (3%) of **20** as a pale yellow oil: IR (neat) 1705, 1633  $\text{cm}^{-1}$ ;  $^1\text{H}$  NMR ( $\text{CDCl}_3$ , 300 MHz)  $\delta$  0.66–0.95 (m, 17H), 1.19–1.61 (m, 16H), 2.43 (t,  $J = 7.0$  Hz, 2H), 3.15 (d,  $J = 7.0$  Hz), 5.11 (d,  $J = 17.0$  Hz, 1H), 5.16 (d,  $J = 10.1$  Hz, 1H), 5.91 (ddt,  $J = 17.0, 10.1, 7.0$  Hz, 1H);  $^{13}\text{C}$  NMR ( $\text{CDCl}_3$ , 75 MHz)  $\delta$  8.6, 8.7, 13.7, 26.7, 27.4, 28.4, 29.2, 42.0, 47.7, 118.7, 130.8, 209.0; HRMS calcd for  $\text{C}_{16}\text{H}_{31}\text{O}^{120}\text{Sn}$   $m/z$  359.1397, found 359.1417.

**General Procedure for Radical Cyclizations. Radical Cyclization of Bromide 8: 6-(Tributylstannyl)hexanal (22) and 6-(Tributylstannyl)hexanol (23).** To a solution of 553 mg (1.18 mmol) of bromide **8** in 12 mL of benzene heated at 80 °C was added over 6 h a solution of 0.35 mL (1.3 mmol) of tributyltin hydride and 12 mg (0.07 mmol) of AIBN in 12 mL of benzene. The reaction mixture was stirred for another 1 h and then directly analyzed by GC (10% SE-30 on Chromosorb W, 3 m  $\times$  3.3 mm, column temperature = 80 °C, flow rate = 25 mL/min) using nonane as an internal standard ( $t_{\text{R}} = 10.18$  min). We observed the formation of 27% of cyclohexanol ( $t_{\text{R}} = 8.50$  min). The reaction mixture was then concentrated in vacuo followed by the addition of a few drops of triethylamine and then chromatographed over silica gel (eluted in gradient with hexane/ethyl acetate) to give 131 mg (29%) of **22** and 42 mg (9%) of **23** as pale yellow oils. **22**: IR (neat) 1720  $\text{cm}^{-1}$ ;  $^1\text{H}$  NMR (300 MHz)  $\delta$  0.65–0.90 (m, 17H), 1.20–1.69 (m overlapped with a quintet,  $J = 7.5$  Hz, at 1.61, 18H), 2.38 (t,  $J = 7.4$  Hz, 2H), 9.73 (br s, 1H);  $^{13}\text{C}$  NMR (75 MHz)  $\delta$  8.6 (t;  $J_{\text{C-Sn}} = 310$  Hz), 8.7 (t;  $J_{\text{C-Sn}} = 310$  Hz), 13.7 (q), 21.6 (t), 26.7 (t), 27.4 (t;  $J_{\text{C-Sn}} = 60$  Hz), 29.2 (t;  $J_{\text{C-Sn}} = 20$  Hz), 33.9 (t;  $J_{\text{C-Sn}} = 60$  Hz), 43.9 (t), 202.8 (d); HRMS calcd for  $\text{C}_{18}\text{H}_{37}\text{O}^{120}\text{Sn}$  ( $\text{M}^+ - \text{H}$ )  $m/z$  389.1866, found  $m/z$  389.1862. **23**: IR (neat) 3354 (br  $\text{cm}^{-1}$ );  $^1\text{H}$  NMR (300 MHz)  $\delta$  0.66–0.91 (m, 17H), 1.20–1.60 (m, 20H), 1.70 (s, 1H), 3.62 (t,  $J = 6.6$  Hz, 2H);  $^{13}\text{C}$  NMR (75 MHz)  $\delta$  8.7 ( $J_{\text{C-Sn}} = 310$  Hz), 8.9 ( $J_{\text{C-Sn}} = 310$  Hz), 13.7, 25.3, 26.9, 27.3 ( $J_{\text{C-Sn}} = 60$  Hz), 29.2 ( $J_{\text{C-Sn}} = 20$  Hz), 32.8, 34.2 ( $J = 60$  Hz), 63.1; HRMS calcd for  $\text{C}_{18}\text{H}_{39}\text{O}^{120}\text{Sn}$  ( $\text{M}^+ - \text{H}$ )  $m/z$  391.2023, found  $m/z$  391.2031.

**2-(2,6-Dithiacyclohexyl)ethyl-5-hexenal (36).** A solution of 1.9 g (10 mmol) of aldehyde **5** in 10 mL of benzene was added over 10 min to a mixture of 2.3 mL (20 mmol) of cyclohexylamine and 690 mg (5.0 mmol) of sodium carbonate in 7 mL of benzene. The resulting mixture was stirred at room temperature for 1 h, filtered, and then concentrated in vacuo to give the crude imine. To another solution of 1.4 mL (10 mmol) of diisopropylamine in 10 mL of dry THF cooled in an ice–water bath was added over 10 min a solution of 1.6 M butyllithium in hexane (6.3 mL, 10 mmol). The resulting mixture was stirred at the same temperature for another 30 min followed by the addition of a solution of the crude imine in 10 mL of dry THF over a period of 20 min. The reaction mixture was stirred at 0 °C for 1 h and then cooled in a dry ice–acetone bath. To this cooled solution was added dropwise 1.32 mL (13 mmol) of 4-bromo-1-butene. The resulting mixture was slowly warmed to room temperature, stirred for another 4 h, and then poured into 20 mL of a 1 N HCl solution. The resulting mixture

was partitioned between ether (150 mL) and water (100 mL). The organic layer was washed with brine (50 mL), dried ( $\text{MgSO}_4$ ), and concentrated in vacuo. The residue was chromatographed over silica gel (eluted in gradient with hexane/ethyl acetate) to give 1.512 g (62%) of **36** as a pale yellow oil: IR (neat) 1716, 1633  $\text{cm}^{-1}$ ;  $^1\text{H}$  NMR ( $\text{CDCl}_3$ , 300 MHz)  $\delta$  1.45–1.95 (m, 7H), 1.95–2.15 (m, 3H), 2.25–2.35 (m, 1H), 2.75–2.90 (m, 4H), 3.99 (t,  $J = 6.5$  Hz, 1H), 4.94–5.04 (m, 2H), 5.73 (ddt,  $J = 16.9, 10.2, 6.7$  Hz, 1H), 9.56 (t,  $J = 2.5$  Hz, 1H);  $^{13}\text{C}$  NMR ( $\text{CDCl}_3$ , 50 MHz)  $\delta$  25.0, 25.3, 27.1, 29.6, 30.4, 32.1, 46.6, 50.0, 115.0, 137.0, 203.5; HRMS calcd for  $\text{C}_{12}\text{H}_{20}\text{OS}_2$   $m/z$  244.0956, found 244.0970.

**O-[1-(Tributylstannyl)-2-(2-formylethyl)-5-hexenyl] S-Methyl Dithiocarbonate (38).** A mixture of 453 mg (0.72 mmol) of **37**, 304 mg (3.62 mmol) of sodium bicarbonate, 0.67 mL (10.9 mmol) of methyl iodide, 2 mL of acetone, and 0.2 mL of water was stirred under reflux for 16 h and then poured into ether (30 mL) and water (30 mL). The aqueous phase was extracted with 30 mL of ether. The combined organic layers were washed with brine (30 mL), dried ( $\text{MgSO}_4$ ), and concentrated in vacuo. The residue was chromatographed over silica gel (eluted with hexane/ethyl acetate, 92/8) to give 0.27 g (70%) of **38** as a yellow oil: a 1:1 mixture of two diastereomers. IR (neat) 1718, 1633  $\text{cm}^{-1}$ ;  $^1\text{H}$  NMR (300 MHz)  $\delta$  0.82–1.12 (m overlapped with t,  $J = 7.7$  Hz, at 0.87, 15H), 1.28 (s,  $J = 7.2$  Hz, 6H), 1.39–1.98 (m, 10H), 1.98–2.34 (m, 3H), 2.37–2.64 (m overlapped with a s at 2.52, 5H), 4.91–5.10 (m, 2H), 5.67–5.86 (m, 1H), 5.96 (d,  $J = 5.9$  Hz, 0.5H, OCH of one isomer), 6.04 (d,  $J = 4.1$  Hz, 0.5H, OCH of another isomer), 9.71–9.80 (two overlapped t,  $J = 1.5$  Hz, at 9.75 and 9.76, 1H). Anal. Calcd for  $\text{C}_{23}\text{H}_{44}\text{O}_2\text{S}_2\text{Sn}$ : C, 51.60; H, 8.28. Found: C, 51.21; H, 8.30.

**Dimethyl 2-(5-Trimethylsilyl-4-pentynyl)-2-[2-(2,6-dithiacyclohexyl)ethyl]propanedioate (44).** To a mixture of 518 mg (17.3 mmol) of sodium hydride (80% dispersed in mineral oil) in 17 mL of dry DMF cooled in an ice–water bath was added over 15 min a solution of 4.00 g (14.4 mmol) of diester **43**<sup>15i</sup> in 28 mL of dry DMF. The resulting mixture was stirred at 0 °C for another 30 min followed by the addition of 5.23 g (19.7 mmol) of 5-iodo-1-trimethylsilylpentene.<sup>44</sup> The reaction mixture was stirred at room temperature for 12 h and then partitioned between ether (200 mL) and water (200 mL). The organic layer was washed with brine (100 mL), dried ( $\text{MgSO}_4$ ), and concentrated in vacuo. The residue was chromatographed over silica gel (eluted with hexane/ethyl acetate, 85/15) to give 4.37 g (73%) of **44** as a pale yellow oil: IR (neat) 2173, 1728  $\text{cm}^{-1}$ ;  $^1\text{H}$  NMR ( $\text{CDCl}_3$ , 300 MHz)  $\delta$  0.10 (s, 9H), 1.25–1.48 (m, 2H), 1.53–1.69 (m, 2H), 1.71–1.99 (m, 3H), 1.99–2.27 (m overlapped with a t,  $J = 7.1$  Hz, at 2.18, 5H), 2.71–2.91 (m, 4H, SCH<sub>2</sub>), 3.68 (s, 6H), 3.94 (t,  $J = 6.8$  Hz);  $^{13}\text{C}$  NMR ( $\text{CDCl}_3$ , 75 MHz)  $\delta$  0.1 (q), 20.0 (t), 23.5 (t), 25.8 (t), 29.8 (t), 30.2 (t), 31.8 (t), 47.2 (d), 52.4 (q), 57.0 (s), 85.0 (s), 106.3 (s), 171.5 (s). Anal. Calcd for  $\text{C}_{19}\text{H}_{32}\text{O}_4\text{S}_2\text{Si}$ : C, 54.77; H, 7.74. Found: C, 54.52; H, 7.66.

**Methyl 2-[2-(2,6-Dithiacyclohexyl)ethyl]-7-trimethylsilyl-6-heptynoate (45).** A mixture of 4.37 g (10.5 mmol) of **44** and 617 mg (12.6 mmol) of sodium cyanide in 10 mL of DMF was heated at 120 °C for 16 h and then partitioned between ether (200 mL) and water (200 mL). The organic layer was washed with brine (100 mL), dried ( $\text{MgSO}_4$ ), and concentrated in vacuo. The residue was chromatographed over silica gel (eluted with hexane/ethyl acetate, 95/5) to give 2.39 g (64%) of **45** as a pale yellow oil: IR (neat) 2173, 1732  $\text{cm}^{-1}$ ;  $^1\text{H}$  NMR ( $\text{CDCl}_3$ , 300 MHz)  $\delta$  0.05 (s, 9H), 1.32–1.86 (m, 9H), 1.96–2.09 (m, 1H), 2.12 (t,  $J = 6.7$  Hz, 2H), 2.23–2.38 (m, 1H), 2.64–2.85 (m, 4H), 3.59 (s, 3H), 3.87–3.98 (m, 1H);  $^{13}\text{C}$  NMR ( $\text{CDCl}_3$ , 75 MHz)  $\delta$  0.0 (q), 19.5 (t), 25.8 (t), 26.0 (t), 29.0 (t), 30.1 (t), 31.0 (t), 32.9 (t), 44.4 (d), 47.0 (d), 51.4 (q), 84.7 (s), 106.5 (s), 175.6 (s). Anal. Calcd for  $\text{C}_{17}\text{H}_{30}\text{O}_2\text{S}_2\text{Si}$ : C, 56.94; H, 8.43. Found: C, 56.83; H, 8.19.

**7-Trimethylsilyl-2-[2-(2,6-dithiacyclohexyl)ethyl]-6-heptyn-1-ol (46).** To a mixture of 380 mg (10 mmol) of LAH in 10 mL of dry THF cooled in an ice–water bath was added over 10 min a

solution of 2.39 g (6.68 mmol) of **45** in 7 mL of dry THF. The reaction mixture was stirred at the same temperature for 1 h, diluted with 15 mL of ether, followed by sequential addition of 0.4 mL of water, 0.4 mL of a 15% sodium hydroxide solution, and 0.8 mL of water. The resulting mixture was stirred at room temperature for 30 min, filtered, dried (MgSO<sub>4</sub>), and concentrated in vacuo to give 2.18 g (98%) of **46** as a colorless liquid: IR (neat) 3414 (br), 2172 cm<sup>-1</sup>; <sup>1</sup>H NMR (CDCl<sub>3</sub>, 200 MHz) δ 0.12 (s, 9H), 1.32–1.69 (m, 8H), 1.71–1.92 (m, 3H), 2.03–2.27 (m overlapped with a t, *J* = 7.0 Hz, 3H), 2.75–2.92 (m, 4H), 3.53 (d, *J* = 4.4 Hz, 2H), 4.00 (t, *J* = 6.8 Hz, 1H); <sup>13</sup>C NMR (CDCl<sub>3</sub>, 75 MHz) δ 0.2 (q), 20.1 (t), 25.8 (t), 26.0 (t), 27.8 (t), 29.8 (t), 30.4 (t), 32.7 (t), 39.8 (d), 47.8 (d), 65.2 (t), 84.7 (s), 107.2 (s); HRMS calcd for C<sub>16</sub>H<sub>30</sub>OS<sub>2</sub>Si 330.1507, found 330.1509.

**7-Trimethylsilyl-2-[2-(2,6-dithiacyclohexyl)ethyl]-6-heptyn-1-ol (47).** To a solution of 0.80 mL (9.24 mmol) of oxalyl chloride in 18 mL of dichloromethane cooled in a dry ice–acetone bath was added over 5 min a solution of 1.40 mL (18.5 mmol) of dry DMSO in 5 mL of dichloromethane. The resulting solution was stirred at the same temperature for 5 min followed by the addition of a solution of 2.18 g (6.61 mmol) of **46** in 7 mL of dichloromethane over a period of 5 min. The reaction mixture was stirred at the same temperature for 30 min followed by the addition of 5.50 mL (4.00 mmol) of triethylamine over 5 min, slowly warmed

to room temperature over 30 min, and then filtered over a short pad of silica gel. The filtrate was concentrated in vacuo, and the residue was chromatographed over silica gel (eluted with hexane/ethyl acetate, 9/1) to give 1.93 g (89%) of **47** as a colorless oil: IR (neat) 2173, 1724 cm<sup>-1</sup>; <sup>1</sup>H NMR (CDCl<sub>3</sub>, 300 MHz) δ 0.11 (s, 9H), 1.39–1.91 (m overlapped with a t, *J* = 5.9 Hz, at 1.73, 9H), 2.01–2.14 (m, 1H), 2.16–2.33 (m overlapped with a t, *J* = 6.7 Hz, at 2.21, 3H), 2.85–2.94 (m, 4H), 3.99 (t, *J* = 6.5 Hz, 1H), 9.55 (d, *J* = 2.9 Hz, 1H); <sup>13</sup>C NMR (CDCl<sub>3</sub>, 75 MHz) δ 0.1 (q), 19.8 (t), 25.6 (t), 25.7 (t), 25.8 (t), 27.5 (t), 30.3 (t), 32.7 (t), 47.2 (d), 50.9 (d), 85.2 (s), 106.3 (s), 204.1 (d). Anal. Calcd for C<sub>16</sub>H<sub>28</sub>OS<sub>2</sub>Si: C, 58.51; H, 8.60. Found: C, 58.30; H, 8.26.

**Acknowledgment.** Financial support by the National Science Council of the Republic of China is gratefully acknowledged.

**Supporting Information Available:** Compound characterization data of **8**, **25**, **27–29**, **37**, **40–42**, **48–53**, and **55–66**. <sup>1</sup>H/<sup>13</sup>C NMR spectra of all new compounds, and NOESY spectra of **61a** and **61b**. This material is available free of charge via the Internet at <http://pubs.acs.org>.

JO052176V