

New CVD Precursors Capable of Depositing Copper Metal under Mixed O₂/Ar Atmosphere

Eddy Lay, Yi-Hwa Song, Yuan-Chieh Chiu, Yang-Miin Lin, and Yun Chi*

Department of Chemistry, National Tsing Hua University, Hsinchu 30013, Taiwan

Arthur J. Carty*

Steacie Institute for Molecular Sciences, National Research Council Canada, 100 Sussex Drive, Ottawa, Ontario K1A 0R6, Canada.

Shie-Ming Peng and Gene-Hsiang Lee

Department of Chemistry and Instrumentation Center, National Taiwan University, Taipei 10764, Taiwan

Received May 25, 2005

Volatile low-melting Cu^{II} metal complexes Cu[OC(CF₃)₂CH₂C(Me)=NMe]₂ (**4**) and Cu[OC(CF₃)₂CH₂CHMeNHMe]₂ (**5**) were synthesized and characterized by spectroscopic methods. A single-crystal X-ray diffraction study on complex **4** shows the anticipated N₂O₂ square-planar geometry with the imino alcoholate ligand arranged in the all-trans orientation. In contrast, a highly distorted N₂O₂ geometry with a dihedral angle of 33° was observed for complex **5**, suggesting that the fully saturated amino alcoholate ligand produces a much greater steric congestion around the metal ion. Metal CVD experiments were conducted, showing that both complexes, **4** and **5**, are capable of depositing copper metal at temperatures of 275–300 °C using an inert argon carrier gas mixed with low concentrations (2–8%) of O₂. The best copper thin film showed a purity of ~96 at. % and a resistivity of 2.11 μΩ cm versus that of the bulk standard (1.7 μΩ cm), as revealed by XPS and four-point probe analyses, respectively. We speculate that the low concentration of O₂ promotes partial ligand oxidation, thus releasing the reduced copper on the substrate and affording the high-purity copper deposit.

Copper-based metallization has been introduced into leading-edge microelectronic industries because of its promising physical properties, such as lower resistivity, improved electromigration resistance, and increased resistance to stress-induced formation of voids caused by a higher melting point for copper.¹ The deposition of copper metal films via MOCVD have been achieved by using Cu^{II} complexes, such as Cu(acac)₂ or Cu(hfac)₂ where acac = acetylacetonate and hfac = hexafluoroacetylacetonate.² For example, with Cu(hfac)₂ high-purity copper metal can be obtained at relatively

low temperatures in the presence of an external reducing agent, H₂. This deposition reaction is best represented by the following transformation

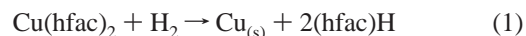

Upon removal of the external reducing carrier gas, H₂, Cu^{II} diketonate source reagents leave an excess of carbon and other contaminants on the thin film because of unwanted heat-induced ligand fragmentation.³

* To whom correspondence should be addressed. Fax: (886) 3 572-0864. E-mail: ychi@mx.nthu.edu.tw.

(1) Griffin, G. L.; Maverick, A. W. In *The Chemistry of Metal CVD*; Kodas, T. T., Hampden-Smith, M. J., Ed.; VCH: Weinheim, Germany, 1994; Chapter 4. (b) Rickerby, J.; Steinke, J. H. G. *Chem. Rev.* **2002**, *102*, 1525. (c) Vertoprakhov, V. N.; Krupoder, S. A. *Russ. Chem. Rev.* **2000**, *69*, 1057. (d) Doppelt, P. *Coord. Chem. Rev.* **1998**, *178*–180, 1785.

(2) Armitage, D. N.; Dunhill, N. I.; West, R. H.; Williams, J. O. *J. Cryst. Growth* **1991**, *108*, 683. (b) Nuesca, G. M.; Kelber, J. A. *Thin Solid Films* **1995**, *262*, 224. (c) Borgharkar, N. S.; Griffin, G. L. *J. Electrochem. Soc.* **1998**, *145*, 347. (d) Utriainen, M.; Kroger-Laukkanen, M.; Johansson, L.-S.; Niinisto, L. *Appl. Surf. Sci.* **2000**, *157*, 151.

(3) Temple, D.; Reisman, A. *J. Electrochem. Soc.* **1989**, *136*, 3525. (b) Kaloyeros, A. E.; Feng, A.; Garhart, J.; Brooks, K. C.; Ghosh, S. K.; Saxena, A. N.; Luehrs, F. *J. Electron. Mater.* **1990**, *19*, 271.

On the other hand, Cu^I complexes have also been developed, for which the best known reagents are the commercially available (hfac)CuL, where L = trimethylvinylsilane⁴ or 2-methyl-1-hexen-3-yne.⁵ These have been used to deposit high-purity copper thin films in the absence of H₂ gas, through a well-established process involving thermally induced disproportionation



In general, high-quality copper metal thin films can be easily obtained using these Cu^I precursors. However, it is worth noting that these complexes are thermally unstable and begin to decompose at elevated temperatures. Thus, these Cu^I complexes need to be stored in a refrigerator or in the presence of a chemical stabilizer, for example with an excess of the π -donor ligand, to improve the thermal stability.⁶ These precautions are undesirable for CVD processes that require elevated temperatures, faster vapor transport, and higher partial pressures of the copper CVD source reagent.

In this paper, we introduce a new series of Cu^{II} CVD precursors, in which the copper metal is chelated by two fluorinated imino alcoholate or amino alcoholate ligands. These precursors exhibit several practical advantages such as easy accessibility and higher volatility as well as the thermal stability attributed to the Cu^{II} systems. Moreover, we also discovered that these precursors can be used to deposit high-purity copper films in the presence of a low concentration of O₂ carrier gas mixed in argon, rather than the typical reductive environment applied to the traditional Cu^{II} β -diketonate source complexes.^{2,3,7}

Experimental Section

General Information and Materials. Mass spectra were obtained on a JEOL SX-102A instrument operating in electron-impact (EI) mode. The thermogravimetric analyses (TGA) were recorded on a Seiko TG/DTA 300 instrument under an atmospheric pressure of argon with a standard flow rate of 100 cm³ min⁻¹ and a heating rate of 10 °C min⁻¹. Microanalyses were carried out at the NSC Regional Instrumentation Center at National Chiao Tung University, Hsinchu, Taiwan. ¹H and ¹³C NMR spectra were recorded on Varian Mercury-400 instruments; chemical shifts are quoted with respect to CDCl₃ for ¹H and ¹³C NMR data,

- (4) Girolami, G. S.; Jeffries, P. M.; Dubois, L. H. *J. Am. Chem. Soc.* **1993**, *115*, 1015. (b) Hampden-Smith, M. J.; Kodas, T. *Polyhedron* **1995**, *14*, 699. (c) Jain, A.; Kodas, T. T.; Corbitt, T. S.; Hampden-Smith, M. J. *Chem. Mater.* **1996**, *8*, 1119. (d) ter Heerdt, M. L. H.; van der Put, P. J.; Schoonman, J. *Chem. Vap. Deposition* **2001**, *7*, 199. (e) Naik, M. B.; Gill, W. N.; Wentorf, R. H.; Reeves, R. R. *Thin Solid Films* **1995**, *262*, 60. (f) Doppelt, P. *Microelectron. Eng.* **1997**, *37–38*, 89. (g) Cavallotti, C.; Gupta, V.; Sieber, C.; Jensen, K. F. *Phys. Chem. Chem. Phys.* **2003**, *5*, 2818.
- (5) Joulaud, M.; Angekört, C.; Doppelt, P.; Mourier, T.; Mayer, D. *Microelectron. Eng.* **2002**, *64*, 107. (b) Chen, T.-Y.; Vaissermann, J.; Ruiz, E.; Senateur, J. P.; Doppelt, P. *Chem. Mater.* **2001**, *13*, 3993.
- (6) Norman, J. A. T.; Robert, D. A.; Hochberg, A. K.; Smith, P.; Peterson, G. A.; Parmeter, J. E.; Applett, C. A.; Omstead, T. R. *Thin Solid Films* **1995**, *262*, 46. (b) Park, M.-Y.; Son, J.-H.; Rhee, S.-W. *J. Mater. Res.* **1999**, *14*, 975.
- (7) Devi, A.; Goswami, J.; Lakshmi, R.; Shivashankar, S. A.; Chandrasekaran, S. *J. Mater. Res.* **1998**, *13*, 687. (b) Bakovets, V. V.; Levashova, T. M.; Dolgovsova, I. P.; Maksimovskii, E. A. *Inorg. Mater.* **2005**, *41*, 19.

respectively. All reactions were performed under N₂ using anhydrous solvents or solvents treated with an appropriate drying reagent.

The Cu metal thin films were studied using an X-ray diffractometer (XRD) with Cu K α radiation. Scanning electron microscopy (SEM) images were recorded on a Hitachi S-4000 system to study the surface morphology. The resistivities were measured using a four-point probe method at room temperature, for which the instrument is assembled using a Keithley 2182 nanovoltmeter and a Keithley 2400 constant current source. The composition of the thin film was determined by X-ray photoelectron spectroscopy (XPS) utilizing a Physical Electronics PHI 1600 system with an Al/Mg dual anode X-ray source. The surface composition in atom percent was measured from XPS spectra collected after 1–2 min sputtering with argon at 4 keV until a constant composition was obtained.

Synthesis of 1. Hexafluoroacetone trihydrate (25 g, 113.6 mmol) in 90 mL of acetone was charged into a 160 mL stainless steel autoclave. The autoclave was slowly heated to 140 °C and maintained at that temperature for 84 h, giving a pale yellow solution with a small amount of a brown precipitate. The solution was then filtered, treated with anhydrous MgSO₄, and concentrated on a rotary evaporator. The oily residue was purified by reduced pressure distillation (2 Torr, 32 °C), giving 21.1 g of the colorless product, (CF₃)₂C(OH)CH₂COMe (**1**, 94.1 mmol, 83%).

Spectral Data of 1. ¹H NMR (400 MHz, CDCl₃, 298 K): δ 6.71 (s, 1H, OH), 2.93 (s, 2H, CH₂), 2.33 (s, 3H, Me).

Synthesis of 2. A 100 mL flask was charged with 3.5 g montmorillonite K10, 30 mL of chloroform, 12.3 g of ligand **1** (55 mmol), and 5.0 g of methylamine (66 mmol, as 40% methanol solution). The mixture was refluxed for 72 h under a N₂ atmosphere. The montmorillonite K10 was then removed by filtration; the filtrate was dried over anhydrous MgSO₄ and concentrated on a rotary evaporator. The resulting oily liquid was purified by reduced pressure distillation (2.3 Torr, 38 °C), giving 10.8 g of colorless (CF₃)₂C(OH)CH₂CMe(=NMe) (**2**, 45.6 mmol, 83%).

Spectral Data of 2. ¹H NMR (400 MHz, CDCl₃, 298 K): δ 3.12 (s, 3H, NMe), 2.67 (s, 2H, CH₂), 1.95 (s, 3H, Me). ¹³C NMR (100 MHz, CDCl₃, 298 K): δ 171.2 (s, 1C, CN), 123.2 (q, 1C, ¹J_{CF} = 287 Hz, CF₃), 76.8 (septet, 1C, ²J_{CF} = 29 Hz, CO), 36.7 (1C, NMe), 32.9 (1C, CH₂), 19.2 (1C, Me).

Synthesis of 3. Lithium aluminum hydride (1.52 g, 40 mmol) was suspended in diethyl ether (20 mL). Compound **2** (4.74 g, 20 mmol) was added dropwise to this, and the mixture was stirred at room temperature for 3 h. Water (2 mL) was then injected dropwise to quench the reaction. The resulting white emulsion was treated with saturated NH₄Cl(aq) (3 mL), and the organic layer was extracted with diethyl ether, dried over anhydrous MgSO₄, filtered, and concentrated on a rotary evaporator. Reduced pressure distillation at 2.2 Torr and 44 °C gave 3.2 g of the colorless liquid ligand (CF₃)₂C(OH)CH₂CHMeNHMe (**3**, 13.4 mmol, 67%).

Spectral Data of 3. ¹H NMR (400 MHz, CDCl₃, 298 K): δ 3.14 (m, 1H, CH), 2.40 (s, 3H, NMe), 1.92 (dd, 1H, ³J_{HH} = 15.2 Hz, 2.8 Hz, CH₂), 1.73 (m, 1H, CH₂), 1.17 (d, 2H, ³J_{HH} = 6.4 Hz, CH₃). ¹³C NMR (100 MHz, CDCl₃, 298 K): δ 124.1 (q, 1C, ¹J_{CF} = 288 Hz, CF₃), 123.2 (q, 1C, ¹J_{CF} = 288 Hz, CF₃), 76.7 (septet, 1C, ²J_{CF} = 29 Hz, CO), 52.0 (1C, CH), 31.9 (1C, CH₂), 31.6 (1C, NMe), 20.0 (1C, Me).

Synthesis of 4. Sodium hydride (0.29 g, 12 mmol) was suspended in 25 mL of THF. Compound **2** (2.37 g, 10 mmol) in 25 mL of THF was added dropwise to this. The mixture was stirred for 2 h until evolution of gas had ceased. The solution was filtered to remove the unreacted NaH, and the filtrate was transferred into a 100 mL flask containing a suspension of CuCl₂ (0.68 g, 5.1 mmol)

in THF (25 mL). The mixture was stirred for 12 h, giving a blue solution with an off-white NaCl precipitate. After the solution was filtered and evaporated to dryness, vacuum sublimation (350 mTorr, 100 °C) yielded 1.97 g of a light purple solid, Cu[OC(CF₃)₂CH₂C(Me)=NMe]₂ (**4**, 3.7 mmol, 72%). Single crystals suitable for X-ray diffraction studies were obtained by diffusion of hexane into a solution of CH₂Cl₂ at room temperature.

Spectral Data of 4. MS (EI, *m/z*, L = C₇H₈F₆NO), observed (actual) [assignment]: 535 (535) [CuL₂], 466 (466) [CuL₂ - CF₃], 369 (369) [CuL₂ - C₃F₆O], 300 (299) [CuL], 236 (236) [L], 230 (230) [CuL - CF₃], 134 (133) [CuL - C₃F₆O], 70 (70) [L - C₃F₆O]. Anal. Calcd for C₁₄H₁₆CuF₁₂N₂O₂: C, 31.38; H, 3.01; N, 5.23. Found: C, 31.51; H, 3.33; N, 5.01.

Synthesis of 5. Procedures identical to those employed to prepare **4** were followed, using 0.288 g of sodium hydride (12 mmol), 2.39 g of ligand **3** (10 mmol), and 0.68 g of CuCl₂ (5.1 mmol). After the THF solvent was removed, vacuum sublimation (250 mTorr, 85 °C) yielded 1.92 g of a light purple solid, Cu[OC(CF₃)₂CH₂-CHMeNHMe]₂ (**5**, 3.6 mmol, 70%). Single crystals suitable for X-ray diffraction studies were obtained by diffusion of hexane into a solution of CH₂Cl₂ at room temperature.

Spectral Data of 5. MS (EI, *m/z*, L = C₇H₁₀F₆NO), observed (actual) [assignment]: 539 (539) [CuL₂], 375 (373) [CuL₂ - C₃F₆O], 302 (301) [CuL], 238 (238) [L], 134 (135) [CuL - C₃F₆O], 71 (72) [L - C₃F₆O]. Anal. Calcd for C₁₄H₂₀CuF₁₂N₂O₂: C, 31.15; H, 3.73; N, 5.19. Found: C, 31.12; H, 3.91; N, 5.38.

X-ray Structural Determination. Single-crystal X-ray diffraction data were recorded on a Bruker SMART CCD diffractometer using Mo K α radiation ($\lambda = 0.71073$ Å). The data collection was executed using the SMART program. Cell refinement and data reduction were made with the SAINT program. The structure was determined using the SHELXTL/PC program, and the refinement was made using full-matrix least-squares refinement. All non-hydrogen atoms were refined anisotropically, for which hydrogen atoms were placed at the calculated positions and included in the final stage of refinements with fixed positional parameters. The crystallographic refinement parameters of complexes **4** and **5** are summarized in Table 1, while the selective bond distances and angles of these complexes are listed in Tables 2 and 3, respectively.

CVD Procedures. The deposition of copper was carried out with a homemade vertical cold-wall reactor as described in previous studies.⁸ The working pressure during deposition was maintained at ~1.5 Torr with a typical background pressure of 1×10^{-3} Torr. The mixed argon gas containing 2 and 8% O₂ was purchased from a local supplier (Chiah Lung Enterprise Co., Ltd. Hsinchu, Taiwan), and their compositional ratios were checked by gas chromatography. The flow rate of the carrier gas was adjusted to 10–20 sccm, and the carrier gas was immediately turned off at the end of the deposition reaction to avoid the oxidation of the as-deposited copper thin film. The carrier gas was then introduced through the sidearm of the sample reservoir, which was loaded with ~250 mg of the source reagent for each CVD experiment. The typical deposition time was adjusted to 10–15 min, while the sample reservoir temperature was reduced to 50 °C and the deposition time was reduced to 3 min for experiments using source reagent Cu(hfac)₂ because of its higher vapor pressure. Before each experiment, the Si wafers were cleaned using a dilute HF solution, which was followed by washing with deionized water and acetone in sequence and drying under nitrogen.

Table 1. X-ray Structural Data for Complexes **4** and **5**

	4	5
formula	C ₁₄ H ₁₆ CuF ₁₂ N ₂ O ₂	C ₁₄ H ₂₀ CuF ₁₂ N ₂ O ₂
mol wt	535.83	539.86
temp	150(1) K	295(2) K
cryst syst	orthorhombic	monoclinic
space group	<i>Pna</i> 2 ₁	<i>P</i> 2 ₁ / <i>n</i>
<i>a</i> (Å)	19.8983(13)	12.0784(8)
<i>b</i> (Å)	8.8891(6)	7.0847(5)
<i>c</i> (Å)	10.7143(7)	13.1862(9)
β (deg)		111.190(1)
<i>V</i> (Å ³)	1895.1(2)	1052.1(1)
<i>Z</i>	4	2
<i>D_c</i> (mg m ⁻³)	1.878	1.704
<i>F</i> (000)	1068	542
cryst size (mm ³)	0.40 × 0.25 × 0.25	0.28 × 0.25 × 0.12
2 θ range (deg)	2.05–27.50	1.96–27.50
index ranges	–25 ≤ <i>h</i> ≤ 25 –11 ≤ <i>k</i> ≤ 9 –12 ≤ <i>l</i> ≤ 13	–15 ≤ <i>h</i> ≤ 15 –9 ≤ <i>k</i> ≤ 9 –17 ≤ <i>l</i> ≤ 17
reflns collected	13171	10153
independent reflns [<i>R</i> _{int}]	4141 [0.0559]	2424 [0.0278]
data/restraints/parameters	4141/1/280	2424/0/141
GOF on <i>F</i> ²	1.093	1.073
final <i>R</i> indices [<i>I</i> > 2 σ (<i>I</i>)]	<i>R</i> 1 = 0.0584, <i>wR</i> 2 = 0.1409	<i>R</i> 1 = 0.0480, <i>wR</i> 2 = 0.1286
<i>R</i> indices (all data)	<i>R</i> 1 = 0.0653 <i>wR</i> 2 = 0.1452	<i>R</i> 1 = 0.0542 <i>wR</i> 2 = 0.1334
largest diff. peak and hole (e Å ⁻³)	1.491 and –1.032	0.438 and –0.344

Table 2. Selected Bond Distances (Å) and Angles (deg) for Complex **4** (esds in parentheses)

Cu–O(1)	1.914(3)	Cu–N(1)	2.018(4)
Cu–O(2)	1.901(3)	Cu–N(2)	2.033(4)
O(1)–C(4)	1.359(6)	N(1)–C(2)	1.284(6)
O(2)–C(11)	1.353(6)	N(2)–C(9)	1.270(7)
C(2)–C(3)	1.511(7)	C(3)–C(4)	1.554(7)
C(9)–C(10)	1.518(7)	C(10)–C(11)	1.545(7)
O(1)–Cu–O(2)	177.4(2)	O(2)–Cu–N(1)	87.35(15)
O(1)–Cu–N(1)	91.11(15)	O(2)–Cu–N(2)	91.41(16)
O(1)–Cu–N(2)	90.13(15)	N(1)–Cu–N(2)	178.75(17)

Table 3. Selected Bond Distances (Å) and Angles (deg) for Complex **5** (esds in parentheses)

Cu–O(1)	1.874(2)	Cu–N(1)	2.023(2)
O(1)–C(4)	1.358(3)	N(1)–C(2)	1.486(4)
C(2)–C(3)	1.504(5)	C(3)–C(4)	1.540(4)
O(1)–Cu–O(1A)	163.93(16)	O(1)–Cu–N(1)	95.51(9)
O(1)–Cu–N(1A)	88.71(9)	N(1)–Cu–N(1A)	149.53(14)

Synthesis and Characterization

The copper CVD source reagents synthesized in this study consisted of a central Cu^{II} metal ion coordinated by two fluorinated imino alcoholate or amino alcoholate chelates. The two electron-withdrawing CF₃ groups on each of the free ligands are expected to increase the acidity of the adjacent hydroxyl group and, in turn, notably improve the stability as well as the volatility of the resulting complexes. On the basis of these considerations, we believe that our new design should provide a much needed improvement in stability compared with those of the nonfluorinated analogues, such as Cu[OCH₂CH₂NMe₂]₂ and Cu[OCHMeCH₂-NEt₂]₂.⁹ The latter are well-known for their poor stability in

(8) Yu, H.-L.; Chi, Y.; Liu, C.-S.; Peng, S.-M.; Lee, G.-H. *Chem. Vap. Deposition* **2001**, *7*, 245. (b) Lai, Y.-H.; Chou, T.-Y.; Song, Y.-H.; Liu, C.-S.; Chi, Y.; Carty, A. J.; Peng, S.-M.; Lee, G.-H. *Chem. Mater.* **2003**, *15*, 2454.

(9) Goel, S. C.; Kramer, K. S.; Chiang, M. Y.; Buhro, W. E. *Polyhedron* **1990**, *9*, 611. (b) Young, V. L.; Cox, D. F.; Davis, M. E. *Chem. Mater.* **1993**, *5*, 1701.

Scheme 1

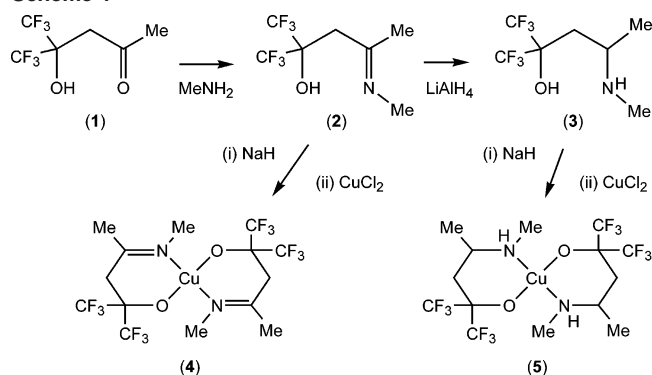

air at room temperature and for their ability to produce high-purity copper metal by CVD at modest temperatures.¹⁰

The synthetic approach to the desired fluorinated imino alcohol and amino alcohol consists of three consecutive steps

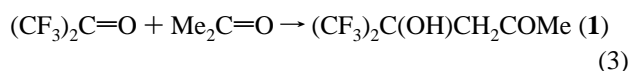

It is important to note that hexafluoroacetone trihydrate was deliberately used to replace anhydrous hexafluoroacetone in the first reaction. By making this modification, we avoided the use of anhydrous hexafluoroacetone, which is a suspected teratogenic reagent, and did not have any reduction in yield or other complications. Thus, our modified protocol is superior to the method originally reported in the literature¹¹ and should be considered as the most satisfactory alternative for the preparation of the fluorinated keto alcohol. With the potential for further ligand functionalization, we fully expect that this method could generate a new class of anionic chelates showing metal-binding properties comparable to those of acetylacetonate or ketoiminates.¹²

This CF₃-substituted keto alcohol was then converted into the related imino alcohol **2** and amino alcohol **3** via condensation with methylamine, followed by treatment with LiAlH₄, respectively (Scheme 1). Subsequently, copper complexes **4** and **5** were synthesized using a method related to that used for the analogous complex Cu[OC(CF₃)₂CH₂NH₂]₂,¹¹ involving a prior treatment of the imino alcohol (or amino alcohol) with excess NaH to generate the anionic ligand fragment, followed by the addition of a CuCl₂ suspended in THF at room temperature.¹³ Vacuum sublimation and recrystallization were routinely used for the ultimate

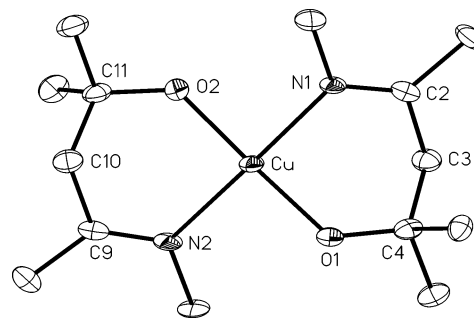

Figure 1. ORTEP drawing of complex **4** with thermal ellipsoids shown at the 50% probability level. All fluorine atoms are removed for clarity.

purification. It is notable that all these copper complexes are highly soluble in solvents such as CH₂Cl₂, THF, and acetone, and their stability in air is comparable to those of the closely related fluoroalkoxo complexes Cu(en)₂(OR_F)₂ and Cu(py)₂(OR_F)₂, where OR_F = hexafluoroisopropoxo and hexafluoro-*tert*-butoxo group.¹⁴

A single-crystal X-ray diffraction study on the imino complex, **4**, was conducted to reveal its molecular structure in the solid state. As indicated in Figure 1, the Cu^{II} metal center shows a planar coordination arrangement with a small dihedral angle of 2.1°, which is calculated using the least-squares planes, Cu–O(1)–N(1) and Cu–O(2)–N(2), defined by the Cu metal atom as well as all donor atoms of each chelating ligand. The imino functional group is clearly identified by the short C–N bond distances (1.271–1.284 Å), which are similar to the C=N distances observed in Schiff base metal complexes.¹⁵ The average Cu–N distance (~2.020 Å) is comparable to the Cu–N distances observed in other complexes, [Cu(hfac)(OCH₂CH₂NMe₂)]₂ (2.020(5) Å)¹⁶ and Cu(hfac)₂(H₂NBu^t) (1.992(4) Å),¹⁷ and is significantly longer than the Cu–O distances observed within this molecule (~1.907 Å) or anhydrous Cu(hfac)₂ (1.91–1.92 Å).¹⁸ Moreover, the imino alcoholate backbones are arranged in a chair conformation, with their unique methylene spacers residing on the opposite side of the N₂O₂ square plane. Similar to that of the many amino alcoholate complexes reported in the literature,¹⁹ the C–C distances adjacent to the alcoholate group (C(3)–C(4) = 1.554(7) Å and C(10)–C(11) = 1.545(7) Å) are found to be notably longer than the other C–C single bonds (C(2)–C(3) = 1.511(7) Å and C(9)–C(10) = 1.518(7) Å). This weakening of the C–C bonding could assist in the spontaneous ligand fragmentation which occurs upon heating and could account for the ease of metal deposition.

For purposes of comparison, the X-ray diffraction study on **5** was also examined to reveal any possible effects of the saturated amino alcoholate ligand. As depicted in Figure 2,

(10) Hambrock, J.; Becker, R.; Birkner, A.; Weiss, J.; Fischer, R. A. *Chem. Commun.* **2002**, 68. (b) Becker, R.; Devi, A.; Weiss, J.; Weckenmann, U.; Winter, M.; Kiener, C.; Becker, H.-W.; Fischer, R. A. *Chem. Vap. Deposition* **2003**, 9, 149.
 (11) Chang, I.-S.; Willis, C. J. *Can. J. Chem.* **1977**, 55, 2465. (b) Loeb, S. J.; Richardson, J. F.; Willis, C. J. *Inorg. Chem.* **1983**, 22, 2736.
 (12) Tung, Y.-L.; Tseng, W.-C.; Lee, C.-Y.; Chi, Y.; Peng, S.-M.; Lee, G.-H. *Organometallics* **1999**, 18, 864. (b) Chi, Y.; Hsu, P.-F.; Liu, C.-S.; Ching, W.-L.; Chou, T.-Y.; Carty, A. J.; Peng, S.-M.; Lee, G.-H.; Chuang, S.-H. *J. Mater. Chem.* **2002**, 12, 3541.
 (13) Chang, C.-H.; Hwang, K. C.; Liu, C.-S.; Chi, Y.; Carty, A. J.; Scoles, L.; Peng, S.-M.; Lee, G.-H.; Reedijk, J. *Angew. Chem., Int. Ed.* **2001**, 40, 4651.

(14) Jeffries, P. M.; Wilson, S. R.; Girolami, G. S. *Inorg. Chem.* **1992**, 31, 4503.
 (15) Luo, H.; Fanwick, P. E.; Green, M. A. *Inorg. Chem.* **1998**, 37, 1127.
 (16) Pinkas, J.; Huffman, J. C.; Bollinger, J. C.; Streib, W. E.; Baxter, D. V.; Chisholm, M. H.; Caulton, K. G. *Inorg. Chem.* **1997**, 36, 2930.
 (17) Woo, K.; Paek, H.; Lee, W. I. *Inorg. Chem.* **2003**, 42, 6484.
 (18) Maverick, A. W.; Fronczek, F. R.; Maverick, E. F.; Billodeaux, D. R.; Cygan, Z. T.; Isovitsch, R. A. *Inorg. Chem.* **2002**, 41, 6488.
 (19) Breeze, S. R.; Wang, S.; Chen, L. *J. Chem. Soc. Dalton Trans.* **1996**, 1341.

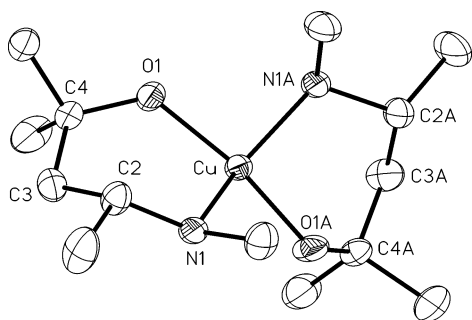

Figure 2. ORTEP drawing of complex **5** with thermal ellipsoids shown at the 25% probability level. All fluorine atoms are removed for clarity.

Chart 1

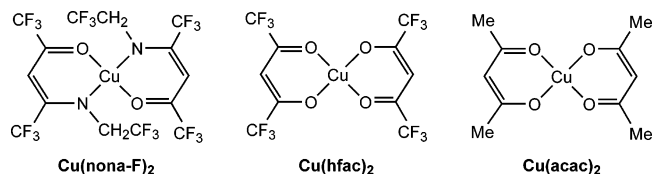

Table 4. Thermal Properties of the Cu^{II} Precursors

compd	formula	mp	T_{dec}	$T_{1/2}^a$	wt % ^b
4	Cu[OC(CF ₃) ₂ CH ₂ C(Me)=NMe] ₂	152–153	231	179	4.45
5	Cu[OC(CF ₃) ₂ CH ₂ CHMeNHMe] ₂	119–120	277	196	0.62

^a The temperature at which 50 wt % of the sample was lost during TG analysis. ^b Residual wt % of the sample observed at 350 °C.

this complex shows a slightly more distorted square-planar arrangement at the copper metal center. The average Cu–O distance of 1.874 Å is slightly shortened, while the Cu–N distances of 2.023 Å (av) remain relatively unchanged with respect to those of the previously examined complex **4**. Two methyl groups around the C–N segment of each amino alcoholate chelate adopt the trans disposition. It can be seen that the fully saturated chelating ligand has caused an enlarged chelate bite angle (95.51(9)° in **5** compared to 91.11(15)° in **4**) as well as a larger dihedral angle of ~33° between the chelating amino alcoholate ligands of **5**. For comparison, a highly distorted square-planar configuration has also been observed in the ketoiminate complex Cu(nona-F)₂, nona-F = CF₃C(O)CHC(NCH₂CF₃)CF₃ (Chart 1).²⁰ In the latter case, the dihedral angle between the two planes defined by the ligands is twisted by 40°, showing a structural distortion possibly imposed by the CF₃CH₂ substituent on the nitrogen atom.

CVD Studies

Thermogravimetric (TG) analysis of both **4** and **5** shows a single-step weight loss pattern in the interval between 100–220 °C and leads to the formation of a dark-red lustrous residue under an argon atmosphere upon raising the temperature to 350 °C. These thermal characteristics are listed in Table 4. It can be seen that the detected residual weights for both samples are much smaller than the theoretical wt % of the copper metal present in each individual sample

Table 5. Deposition Parameters and the Analytical Data of Copper Thin Films^a

compd	T_{sub} (°C)	carrier	thickness (Å)	dep. rate (Å/min)	resistivity (μΩ cm)	composition Cu/C/O (at. %)
4	275	Ar	2363	157.5	4.27	84/13/4
4	300	Ar	1912	127.5	19.46	71/23/6
5	275	Ar	3040	202.7	17.02	74/24/2
5	300	Ar	4540	302.7	101.59	51/41/8
4	275	2% O ₂	1360	90.7	4.89	87/9/4
4	300	2% O ₂	2318	154.5	8.76	86/9/5
5	275	2% O ₂	1882	125.5	2.77	93/5/2
5	300	2% O ₂	2481	165.4	2.87	92/5/3
5	275	8% O ₂	2641	176.1	1.98	95/4/1
5	300	8% O ₂	3599	239.9	2.11	96/3/1
Cu(hfac) ₂	275	2% O ₂	2370	790	14.8	74/15/11
Cu(hfac) ₂	300	2% O ₂	2690	867	10.6	83/6/11

^a T_{sub} represents the substrate temperature, and a 200 Å layer of Pt was deposited onto the Si wafer to improve the copper deposition for experiments using Cu(hfac)₂ as a source reagent.

(~11.8 wt %), implying that direct volatilization, not sample decomposition, is the major process during TG analysis.

As both Cu^{II} complexes **4** and **5** showed good volatility, we then started to investigate their chemical behavior by conducting copper CVD experiments. The first set of reactions was performed using source reagent **5** and argon carrier gas in the temperature range of 275–300 °C. Experimental parameters for the deposition of copper films on the Si (100) substrate are summarized in Table 5. For each of the CVD experiments, the source reagent (~250 mg) was vaporized at 80 °C, with the carrier gas flow rate adjusted to 10–20 sccm under a pressure of 1.5 Torr. Generally speaking, the films deposited at 275 °C showed slightly higher purity and lower resistivity than that obtained at 300 °C. Subsequent XPS measurements indicated the incorporation of ~24 and ~2 at. % of carbon and oxygen impurities even at 275 °C, confirming that this source reagent is not very suitable for deposition of copper metal under an inert argon atmosphere. Similar behavior was confirmed for experiments using complex **4** as the CVD precursor.

To overcome this apparent obstacle, the deposition of copper was then conducted using a mixed argon gas containing 2% O₂ at temperatures of 250–325 °C. Generally speaking, the reactions conducted at the lower temperature of 250 °C showed an insufficient rate of thin film formation, while at the higher temperature of 325 °C, the deposition of copper mainly occurred at the outlet of transport line, giving very small amounts of copper deposition on the substrate. This observation is consistent with the occurrence of rapid precursor decomposition in the gaseous phase. In contrast, the thin films deposited at 275 and 300 °C gave a red metallic luster and had excellent adhesion to the Si substrate. The SEM photos of these samples, depicted in Figures 3 and 4, exhibit the formation of densely packed microstructures with grain sizes proportional to the increase of deposition temperatures. For complex **5**, it is notable that the thin film appeared to show the smallest grain sizes and surface roughness at 275 °C, and then the grain sizes increased substantially at 300 °C. This observation suggests that the grain growth or the coalescence of grains becomes faster at higher temperatures, which then favors the formation of

(20) Fine, S. M.; Dyer, P. N.; Norman, J. A. T.; Muratore, B. A.; Iampietro, R. L. *Mater. Res. Soc. Symp. Proc.* **1991**, *204*, 415.

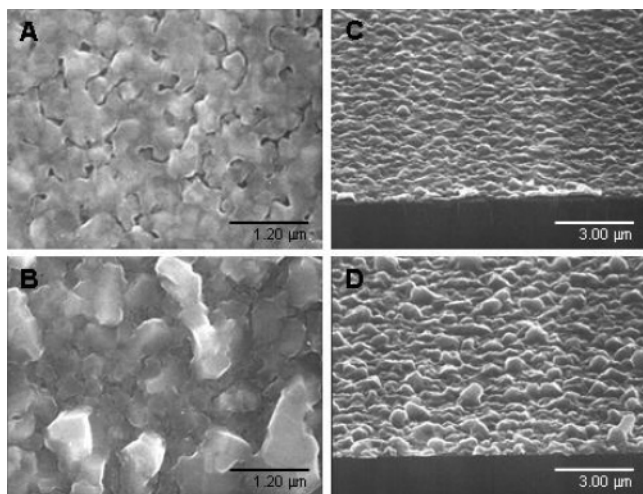

Figure 3. SEM images of copper film deposited from **4** using 2% O₂ in argon at (A) 275 and (B) 300 °C; panels C and D depicted the tilt-view of A and B, respectively.

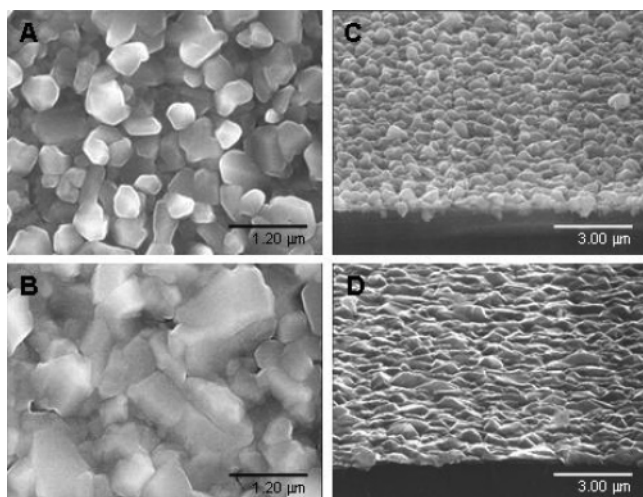

Figure 4. SEM images of copper film deposited from **5** using 2% O₂ in argon at (A) 275 and (B) 300 °C; panels C and D depicted the tilt-view of A and B, respectively.

larger metal particulates.²¹ Preliminary XPS analysis for films deposited using **4** as the source reagent shows the presence of $\geq 86\%$ copper metal, along with approximately 9% carbon and 5% oxygen at 275–300 °C; other impurities such as fluorine and nitrogen atoms were not observed during the XPS survey scan. For thin films deposited using source reagent **5**, the copper content increased to 92%, while the carbon and oxygen impurities were reduced to 5% and 3%, respectively. In good agreement with the high purity, four-point probe measurements of this thin film gave a resistivity as low as $2.77 \mu\Omega \text{ cm}$, which is slightly higher than that of bulk copper metal ($1.7 \mu\Omega \text{ cm}$).

On the basis of the above observations, it is possible that the fully saturated amino alcoholate complex **5** would have an enhanced reactivity with respect to O₂ in a mixed carrier gas. The proposed deposition mechanism consists of the O₂-

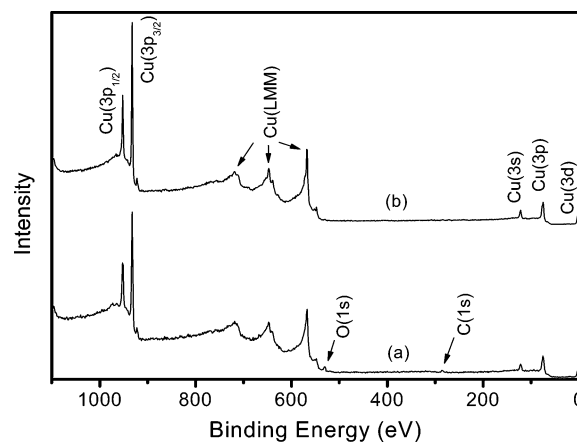

Figure 5. XPS spectra of the copper films deposited from **5** at 275 °C using (a) pure argon and (b) 2% O₂ in argon.

induced partial oxidation of the ligand. This reaction would deplete the O₂ concentration in the carrier gas and result in effective copper deposition with reduced impurity content. The representative XPS spectra of the thin film samples deposited using **5** at 275 °C under inert argon and 2% O₂ in argon are shown in Figure 5. In addition to the signals derived from the copper, weak oxygen and carbon signals centered at 531.5 and 284.5 eV can be seen in these spectra. Their atomic contents are then calculated using the integration area under each peak divided by their sensitivity factors.

The possible influence of supplementary O₂ during the CVD experiments was further examined by increasing the relative proportion of O₂ to 8% in argon. For the imino alcoholate complex **4**, deposition of a dark brown coating was observed at the temperature interval of 275–300 °C, for which the extremely high resistivities correspond to the formation of oxidized CuO or Cu₂O coatings. On the other hand, high-quality copper films can be deposited on the Si substrate using the amino alcoholate chelate **5**. As indicated in Table 5, the XPS and four-point probe analyses show that one thin film possesses the highest copper content of ~ 96 at. % with the lowest resistivity among all the thin film samples obtained in this study. Again, the function of the amino alcoholate versus that of imino alcoholate remains uncertain, but it seems that the amino alcoholate ligand in **5** allows efficient consumption of supplementary O₂ in the carrier gas; otherwise, the remaining O₂ in carrier gas would react with the as-deposited copper, leading to the formation of oxidized materials such as Cu₂O or CuO during CVD runs.²² This hypothesis is verified by a final increase of the O₂/Ar ratio to 20%, for which generation of metal oxides such as Cu₂O and CuO was clearly obtained.

For further comparison, we performed the deposition using the commercially available Cu(hfac)₂ reagent as well as the above-mentioned carrier gas. Interestingly, for the control experiments using a Si wafer as the substrate, no obvious thin film deposition was observed in the temperature range

(21) Kim, D.-H.; Wentorf, R. H.; Gill, W. N. *J. Electrochem. Soc.* **1993**, *140*, 3273. (b) Gladfelter, W. L. *Chem. Mater.* **1993**, *5*, 1372. (c) Lee, W.-J.; Min, J.-S.; Rha, S.-K.; Chun, S.-S.; Park, C.-O. *J. Mater. Sci. Mater. Electron.* **1996**, *7*, 111. (d) Semaltianos, N. G.; Pastol, J.-L.; Doppelt, P. *Surf. Sci.* **2004**, *562*, 157.

(22) Condorelli, G. G.; Malandrino, G.; Fragalá, I. L. *Chem. Vap. Deposition* **1999**, *5*, 21. (b) Medina-Valtierra, J.; Ramirez-Ortiz, J.; Arroyo-Rojas, V. M.; Bosch, P.; de los Reyes, J. A. *Thin Solid Films* **2002**, *405*, 23. (c) Condorelli, G. G.; Malandrino, G.; Fragalá, I. L. *Chem. Mater.* **1994**, *6*, 1861.

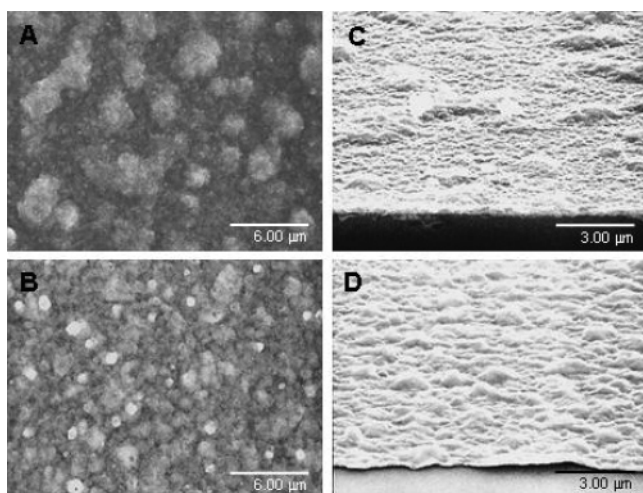

Figure 6. SEM images of copper film deposited from $\text{Cu}(\text{hfac})_2$ using 2% O_2 in argon at (A) 275 and (B) 300 °C; panels C and D depicted the tilt-view of A and B, respectively.

of 275–300 °C, showing that 2% O_2 in argon is insufficient to initiate the anticipated copper deposition, despite the fact that pure copper metal free from carbon contamination was documented using $\text{Cu}(\text{acac})_2$ and a lower concentration of O_2 partial pressure.²³ This evidence confirmed that the O_2 -induced copper deposition relied critically on the chemical reactivity of the source reagents. On the other hand, the growth of copper became much more facile upon switching the substrate from a Si wafer to a sputtered Pt film, which has been used as the preferred growth substrate for the $\text{Cu}(\text{hfac})_2$ source reagent.²³ The XPS study showed that the level of purity appears to be inferior to those obtained in previous studies, while the SEM analysis indicated the formation of relatively smaller particulates with small voids and cracks at the grain boundaries (Figure 6). We speculated that this variation of surface morphology is most likely caused by changing the substrates, with the higher electrical conductivity of Pt metal compared with the less conductive dielectric surface such as Si or SiO_2 lowering the deposition temperatures.²⁴ Moreover, the high catalytic activity known for Pt metal could also enhance the surface reaction between the adsorbed copper reagents and O_2 , which would then reduce the barrier to the deposition and nucleation process, yielding smaller crystallites on the substrate.

Discussion

Cu^{II} -based complexes have been extensively used to produce high-purity copper-containing thin film materials using the CVD technique. This class of complexes includes fluorinated and nonfluorinated β -diketonates, Schiff base precursors, and amino alcoholate complexes: some representative structural drawings are depicted in Charts 1 and 2. It was thus anticipated that changing the ligand design might

Chart 2

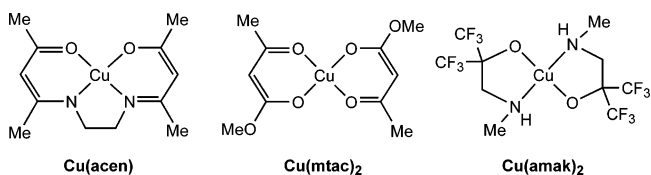

Scheme 2

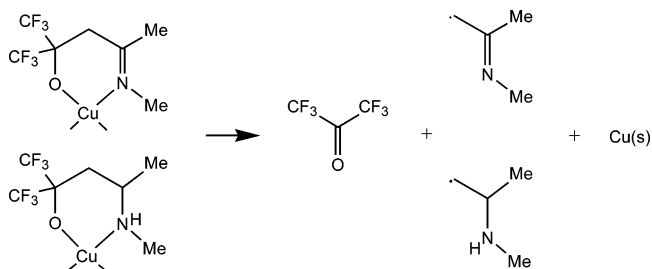

have a dramatic impact on the performance of these complexes for copper CVD studies.

The most intensively investigated source reagents in the literature are the β -diketonate complexes $\text{Cu}(\text{hfac})_2$ and $\text{Cu}(\text{acac})_2$. For depositions conducted under an inert carrier gas, thermally induced ligand decomposition eventually occurs because of the higher reaction temperatures, resulting in anticipated copper films with a high level of contamination. In contrast, typical metal depositions are best conducted using H_2 carrier gas to facilitate thermal reduction at the lower temperatures; while deposition conducted under high partial pressures of O_2 leads to the formation of oxides CuO or Cu_2O depending on the concentration ratio of O_2 to the volatile Cu source, such as $\text{Cu}(\text{acen})$.²⁵ Recently, a further variation was introduced by replacing the β -diketonate complexes with β -ketoesterates such as $\text{Cu}(\text{mtac})_2$: the latter are known for their weaker metal–ligand bonding and higher tendency for the ligands to produce volatile organic species in a controllable manner.^{7a,26} Plasma-enhanced chemical vapor deposition (PECVD) studies have also been attempted to take advantage of the high reactivity of the ligands.²⁷

With the above observations in mind, we argued that our imino alcoholate and amino alcoholate complexes **4** and **5** should display a conceptually related ligand dissociation and decomposition without the need for a reducing gas. This possibility was anticipated from our previous studies of the related amino alcoholate complex $\text{Cu}(\text{amak})_2$, for which heating under an inert atmosphere facilitated copper metalization via a concomitant ligand decomposition to produce free amine and hexafluoroacetone.^{12b,28} Therefore, we believe that complexes **4** and **5** should be capable of depositing copper metal via related C–C bond heterolysis at the nearby alcoholate unit, leading to the formation of hexafluoroacetone and associated radical fragments (Scheme 2). It was thus expected that trace amounts of O_2 in the carrier gas would

- (23) Condorelli, G. G.; Malandrino, G.; Fragalà, I. *Chem. Mater.* **1995**, *7*, 2096. (b) Hammadi, Z.; Lecochier, B.; Dallaporta, H. *J. Appl. Phys.* **1993**, *73*, 5213.
 (24) Chiou, J.-C.; Juang, J.-C.; Chen, M.-C. *J. Electrochem. Soc.* **1995**, *142*, 177. (b) Kim, Y. S.; Kim, D. J.; Kwak, S. K.; Kim, E. K.; Min, S.-K.; Jung, D. *Jpn. J. Appl. Phys. Part 2* **1998**, *37*, L462.

- (25) Condorelli, G. G.; Malandrino, G.; Fragalà, I. L. *Chem. Vap. Deposition* **1999**, *5*, 237.
 (26) Hwang, S.; Choi, H.; Shim, I. *Chem. Mater.* **1996**, *8*, 981.
 (27) Hwang, S. T.; Shim, I.; Lee, K. O.; Kim, K. S.; Kim, J. H.; Choi, G. J.; Cho, Y. S.; Choi, H. *J. Mater. Res.* **1996**, *11*, 1051.
 (28) Hsu, P.-F.; Chi, Y.; Lin, T.-W.; Liu, C.-S.; Carty, A. J.; Peng, S.-M. *Chem. Vap. Deposition* **2001**, *7*, 28.

react with the dissociated organic radicals, suppressing hydrocarbon contamination on the substrate. Finally, among the reaction byproducts collected using a liquid N₂ cold trap, only hexafluoroacetone and trace amounts of the chelating ligands could be identified using ¹⁹F NMR analysis, providing preliminary support for our mechanistic delineation.

Summary

Two complexes, **4** and **5**, in the copper 2+ oxidation state were prepared and studied as possible precursors for the fabrication of copper thin films by thermal CVD methods. In contrast to previously described Cu^{II} CVD precursors, they proved to be easily purified, showed a greater stability at lower temperatures, and can be cleanly converted to copper metal in the temperature range of 275–300 °C, making them very suitable source reagents for depositing copper via the CVD method.

The copper thin films were deposited using both pure argon and low concentrations of O₂ (2–8%) in argon as the carrier gas. The mixing of O₂ in the argon carrier gas seems to have the desirable effect of increasing the purity and

lowering the resistivity of the deposited films. This result shows that low concentrations of O₂ in carrier gas solve both of the problems associated with greater impurities and inevitable metal oxidation. Although such a deposition strategy has been widely applied to noble metal elements such as Ru, Pd, Ir, and Pt,²⁹ there is only a few precedences for application to Cu metal deposition,²³ for which metal oxidation is expected to occur rapidly at elevated temperatures. The exact roles of oxygen in these experiments are not fully understood; however, because of its low concentration, ongoing ligand oxidation may completely deplete the oxygen present, which would then lower the possibility of copper oxidation. Finally, our success in depositing copper under such a low concentration of O₂ implies that the same approach could also be suitable for advanced techniques, such as atomic layer deposition (ALD), and pave the way to the growth copper thin films by ALD using these Cu^{II} source reagents under a well-controlled oxidative environment.

Acknowledgment. We would like to thank the National Science Council of Taiwan for Grant NSC 93-2113-M-007-011.

Supporting Information Available: X-ray crystallographic data file (CIF) of complexes **4** and **5**. This material is available free of charge via the Internet at <http://pubs.acs.org>.

IC050845H

(29) Zhang, Y.; Choi, S. W.-K.; Puddephatt, R. J. *J. Am. Chem. Soc.* **1997**, *119*, 9295. (b) Chen, Y.-L.; Liu, C.-S.; Chi, Y.; Carty, A. J.; Peng, S.-M.; Lee, G.-H. *Chem. Vap. Deposition* **2002**, *8*, 17. (c) Aaltonen, T.; Alen, P.; Ritala, M.; Leskela, M. *Chem. Vap. Deposition* **2003**, *9*, 45.