

This article was downloaded by: [National Taiwan University]

On: 27 October 2009

Access details: Access Details: [subscription number 905688740]

Publisher Taylor & Francis

Informa Ltd Registered in England and Wales Registered Number: 1072954 Registered office: Mortimer House, 37-41 Mortimer Street, London W1T 3JH, UK

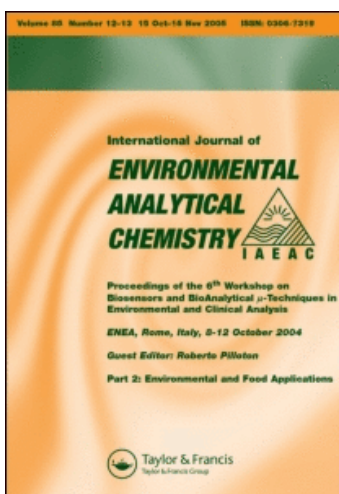

International Journal of Environmental Analytical Chemistry

Publication details, including instructions for authors and subscription information:

<http://www.informaworld.com/smpp/title-content=t713640455>

Determination of Nano-Molar Levels of Nitrite in Natural Water by Spectrophotometry After Pre-Concentration Using Sep-Pak C₁₈ Cartridge

Su-Cheng Pai ^a; Shi-Wei Chung ^a; Tung-Yuan Ho ^{ab}; Yung-Jing Tsau ^c

^a Institute of Oceanography, National Taiwan University, Taiwan, R.O.C. ^b Marine Science Research Center, State University of New York at Stony Brook, Stony Brook, N. Y. ^c Department of Oceanography, National Taiwan Ocean University, Keelung, Taiwan, R.O.C.

Online Publication Date: 01 March 1996

To cite this Article Pai, Su-Cheng, Chung, Shi-Wei, Ho, Tung-Yuan and Tsau, Yung-Jing(1996)'Determination of Nano-Molar Levels of Nitrite in Natural Water by Spectrophotometry After Pre-Concentration Using Sep-Pak C₁₈ Cartridge',International Journal of Environmental Analytical Chemistry,62:3,175 — 189

To link to this Article: DOI: 10.1080/03067319608028132

URL: <http://dx.doi.org/10.1080/03067319608028132>

PLEASE SCROLL DOWN FOR ARTICLE

Full terms and conditions of use: <http://www.informaworld.com/terms-and-conditions-of-access.pdf>

This article may be used for research, teaching and private study purposes. Any substantial or systematic reproduction, re-distribution, re-selling, loan or sub-licensing, systematic supply or distribution in any form to anyone is expressly forbidden.

The publisher does not give any warranty express or implied or make any representation that the contents will be complete or accurate or up to date. The accuracy of any instructions, formulae and drug doses should be independently verified with primary sources. The publisher shall not be liable for any loss, actions, claims, proceedings, demand or costs or damages whatsoever or howsoever caused arising directly or indirectly in connection with or arising out of the use of this material.

DETERMINATION OF NANO-MOLAR LEVELS OF NITRITE IN NATURAL WATER BY SPECTROPHOTOMETRY AFTER PRE- CONCENTRATION USING SEP-PAK C₁₈ CARTRIDGE

SU-CHENG PAI*, SHI-WEI CHUNG, TUNG-YUAN HO
and YUNG-JING TSAU[#]

*Institute of Oceanography, National Taiwan University, P.O. Box 23–13, Taiwan,
R.O.C. [#]Department of Oceanography, National Taiwan Ocean University, Keelung,
Taiwan, R.O.C.*

(Received, 22 December 1994)

Nitrite in natural water was allowed to react with sulphanilamide (SUL) and N-1-naphthylethylenediamine (NED) reagents to form a pink azo dye, which was quantitatively adsorbed onto a Sep-Pak C₁₈ cartridge and was later recovered by eluting with a mixture containing 38% v/v ethanol and 60 mM HCl. The percolate was measured by a spectrophotometer at 543 nm. The molar extinction coefficient of the dye in the final solution was found to be $5 \times 10^4 \text{ M}^{-1} \text{ cm}^{-1}$. Using the proposed manual procedure, nitrite in up to 500 mL of freshwater and 1.5 L of seawater could be concentrated to a final 10 mL with a recovery of > 98%. The detection limit was found to be 0.6 nM and 0.2 nM for 500 mL and 1.5 L sizes of sample. A precision of less than 2% at 20–80 nM level could be readily achieved. The cartridge also served for the preservation purpose, as the bound pink azo dye could be stored for up to 4 days without significant change. The proposed manual procedure has been automated by a cycling loop system to suit ship-board determination.

KEY WORDS: Nitrite, natural waters, solid phase extraction.

INTRODUCTION

Nitrite usually exists in oxic water at very low concentrations because of its unstable nature. It is an intermediate product in the oxidation or reduction reactions between ammonium and nitrate. The measurements of nitrite (together with ammonia and nitrate) give important information in the calculation of the flux of either nitrification or denitrification processes in the environment. It is also of value in the studies of new production and growth limitation in the marine euphotic zone¹. However, since the concentration of nitrite in the upper layer of the ocean is usually very low, traditional methods might not provide required sensitivity. At present, spectrophotometry which

*To whom correspondence should be addressed.

Present address for Tung-Yuan Ho: Marine Science Research Center, State University of New York at Stony Brook, Stony Brook, N.Y. 11794-5000

based on the formation reaction of an intensively colored pink azo dye is still the most widely used method². Its detection limit reaches ca. 30 nM if using a 1 cm standard cuvette (equivalents to an instrumental reading of 0.001). This detection limit can be lowered to ca. 10 nM if using a long 10 cm cuvette³. Below these concentration levels, other high-sensitivity techniques (such as chemiluminescent analysis⁴) or a pre-concentration procedure would be needed.

In this paper a solid extraction technique using the Spe-Pak C₁₈ cartridge for the pre-concentration has been proposed. The Sep-Pak C₁₈ cartridge, packed with resins having a strong adsorbing functional group -Si(CH₃)₂C₁₈H₃₇, has been widely applied to extract organic substances from natural water⁵. According to the manufacturers' suggestion, the analyte that is being adsorbed by the cartridge can be subsequently recovered by eluting with methanol, ethanol, or other organic solvents. In a preliminary test we have found that the adsorption of the pink azo dye onto the Sep-Pak C₁₈ resin was very efficient indeed, but the recovery with direct alcohol elution led to rapid fading of the dye color. To solve this problem the feasibility of using a combined eluent (containing both ethanol and acid) has been studied for recovering the dye without losing its absorptivity.

MATERIALS AND METHODS

Reagents

Water. The water used in this study was purified by a Milli-Q system after a prior Milli-RO plus double-distillation process.

Acidic sulphanilamide reagent (SUL). This reagent was prepared by dissolving 1 g of sulphanilamide in 100 mL of 15% v/v HCl.

Naphthylethylenediamine reagent (NED). This reagent was prepared by dissolving 0.1 g of N-1 naphthylethylenediamine hydrochloride in 100 mL of water.

Ethanol eluent. It was prepared by mixing 40 mL of 95% v/v ethanol and 5 mL of 1.2 M hydrochloric acid, and diluted to 100 mL. This solution contained ca. 38% v/v ethanol in 60 mM HCl.

Reagent blank effluent (RBE). It was prepared by passing the mixture of 500 mL of Milli-Q water and 20 mL-aliquots of each reagent through a Sep-Pak C₁₈ cartridge and collecting the effluent in a polypropylene bottle. This solution, almost free of contaminant, was used in the automated cycling loop system for washing the tubings and the cartridge to avoid air bubbles in the closed loop. For analyzing seawater samples, a reagent blank effluent made from seawater (SW-RBE) was also prepared in a similar way for the same purpose.

Standard

Nitrite standard. A 5000 μM stock nitrite standard solution was made by dissolving 0.345 g of sodium nitrite in 1 L of Milli-Q water. Working standards were freshly prepared by diluting the stock solution to the desired concentrations.

Pink azo dye solution. This was prepared by adding in sequence to a known standard nitrite solution with 4% v/v of SUL and 4% v/v NED reagents.

Sep-Pak C₁₈ cartridge

The Sep-Pak C₁₈ cartridges (Classic, short-body, Part no. WAT51910) were purchased from Waters Chromatographic Division, Millipore, Milford, Massachusetts, U.S.A. Each cartridge contained ca. 0.36 g of the resin. Using a syringe, new cartridges were activated by passing through a 10 mL-aliquot of 95% v/v ethanol and then by washing it with a 30 mL-aliquot of Milli-Q water. Used cartridges were regenerated by the same procedure as for the new ones. In our experience, each cartridge could be re-used for at least ten determinations.

Breakthrough test

Aliquots of up to 6 L of nitrite-spiked sample (concentration = 1, 10, and 20 μM) were added with 4% v/v of SUL and 4% v/v of NED reagents. Each solution was allowed to pass through the Sep-Pak C₁₈ cartridge at a given flow rate. The flow rate was controlled by an Ismatec IPS-8 peristaltic pump (two purple-purple labeled pumping tubes were used in parallel). The effluent was connected to a 1 cm flow cuvette (capacity 71 μL) installed in a Shimadzu 160A spectrophotometer and its absorbance was monitored continuously at 543 nm. The time of half-concentration breakthrough (t_h) was defined as the time when the absorbance of the effluent reaches to half of its original value. The volume of half-concentration breakthrough (V_h) was defined by: $V_h = t_h \times F$; where F is the flow rate in mL min⁻¹ unit.

Manual procedure

An aliquot of sample (up to 500 mL and 1.5 L for freshwater and seawater respectively) was added in sequence with 4% v/v of SUL reagent and 4% v/v of NED reagent. The mixture was shaken for homogeneity and after 5 min wait for complete color development, it was allowed to pass through a Sep-Pak C₁₈ cartridge at a flow rate of no more than 30 mL min⁻¹ controlled by an Ismatec IPS-8 peristaltic pump (Figure 1). The elution from the cartridge was carried out with a syringe, by pushing the eluent (containing 38% v/v ethanol and 60 mM HCl) in a reverse direction at a flow rate no more than 5 mL min⁻¹. Exact 10.0 mL of the percolate was collected in a graduated flask (also see Figure 1). The final yield was measured within 1 hour at 543 nm, using a standard 1 cm cuvette. The reagent blank was estimated by adding reagents to a Milli-Q water following the same procedure for the sample.

The concentration of nitrite in the sample was calculated by:

$$[\text{NO}_2^-](\text{nM}) = \frac{\text{Abs(Corr)}}{\epsilon \times b} \times \frac{\text{Final volume}}{\text{Sample volume}} \times 10^9 \quad (1)$$

where Abs(Corr) is the corrected absorbance reading (reagent blank was subtracted) at 543 nm; ϵ is the molar extinction coefficient of the pink azo dye in the ethanol eluent, to be $5 \times 10^4 \text{ M}^{-1} \text{ cm}^{-1}$; b is the light path of the cuvette in cm unit.

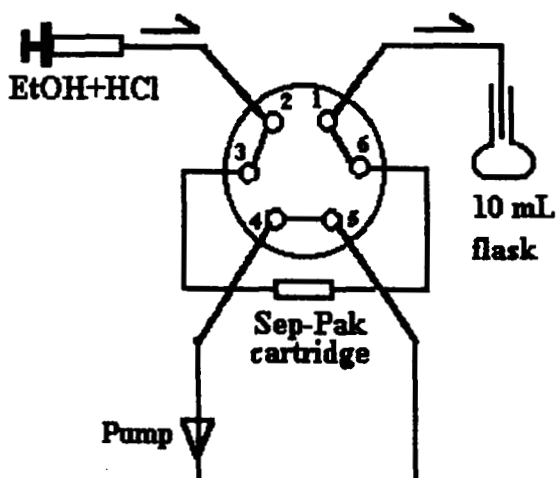
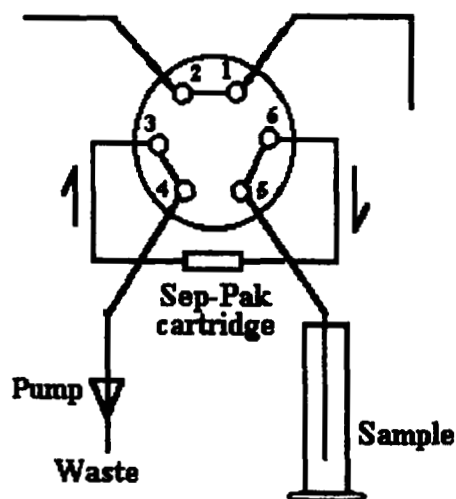

Figure 1 Systematic layout of the manual procedure. (up) Loading mode: Sample (pre-mixed with reagents) was allowed to pass through the Sep-Pak C_{18} cartridge; (down) Desorption mode: Elution was carried out in a reverse direction with a syringe. The eluate was collected in a 10 mL graduated flask.

Cycling loop procedure

For on-board operation, when the accurate volumetric transfer is inconvenient to manage, a cycling loop system has been designed and is illustrated in Figure 2. The system consisted of a 7-port selective valve, two 6-port valves, an on-line Sep-Pak C_{18}

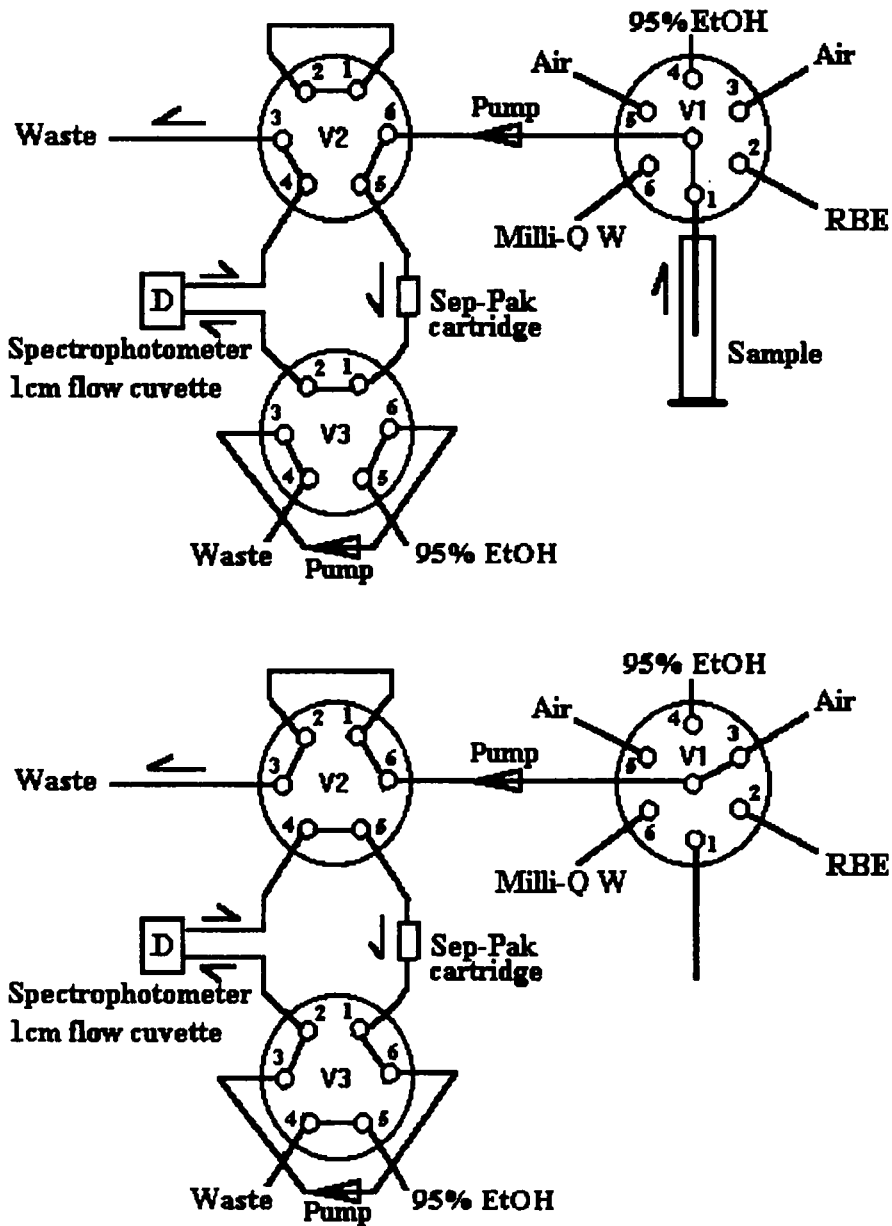

Figure 2 Systematic layout of the automated cycling loop system with an on-line Sep-Pak C_{18} cartridge and an on-line flow cuvette installed in a spectrophotometer. (up) Loading mode: Sample (pre-mixed with reagents) was loaded through valves V1 and V2. After all sample had passed through, V1 was switched to RBE to wash the cartridge and to avoid air bubbles. (down) Cycling mode: The loop was closed by turning V2, then the ethanol was injected by turning V3. The dye was desorbed and recycled within the loop till a final steady state was reached. After the measurement, the loop was opened and the cartridge was re-generated by turning V1 to select sequentially the ethanol, air, and Milli-Q water, then the system was ready for the next sample.

cartridge, and a 1 cm Hellma flow cuvette (capacity 450 μL) installed in a Shimadzu 160A spectrophotometer. The sample was first mixed with appropriate portions of reagents (like the manual procedure), and allowed to stand for 5 minutes for the complete reaction. It was then pumped through a Sep-Pak C_{18} cartridge at a flow rate of no more than 30 mL min^{-1} . After finishing the loading, a 5 mL-aliquot of RBE (reagent blank effluent) was used to wash the resin bed and to remove air bubbles. The loop was closed by turning the valve V2, and the ethanol was injected into the loop by turning the valve V3. The pink azo dye was desorbed from the cartridge when ethanol passed through, as it could be monitored by the spectrophotometer. Since the desorbed fraction was recycled within the loop, peak signals appeared repeatedly on the recorder. After ca. 15 cycles the absorbance reading gradually reached a steady state, and the final reading was taken. The total volume within the loop was estimated by a dye test, to be 4.23 mL, including the volume of the injected eluent of 1.52 mL. The eluent injected was 95% v/v ethanol, thus gave a final acidity of 43 mM and an alcohol concentration of 34% v/v in the loop. Calculation of the nitrite concentration was made according to the calibration curve constructed by running a series known standards.

RESULTS AND DISCUSSION

Absorption spectrum

The absorption spectrum of the pink azo dye was found not only affected by the final acidity but also affected by the concentration of ethanol. Increase of the acidity increased slightly the molar absorption coefficient and the rate of color formation reaction⁶. In aqueous medium the molar absorption coefficient at 543 nm was measured to be ca. $5.3 \times 10^4 \text{ M}^{-1}\text{cm}^{-1}$ at a final acidity of 67 mM, and was slightly lower when the final acidity was low, e.g. to be $5.2 \times 10^4 \text{ M}^{-1}\text{cm}^{-1}$ at 34 mM. The maximum wavelength remained the same. When ethanol was present, the absorption spectrum of the dye was changed. The molar extinction coefficient at 543 nm dropped with the increase of ethanol concentration, and the absorption maximum shifted slightly (Figure 3). A test on a 10 μM nitrite standard using variable acidities and ethanol concentrations was carried out, and the combined effect to the molar extinction coefficient at 543 nm is illustrated in a contour diagram (Figure 4). Those values shown on the diagram indicate a tendency of decrease of absorptivity with the decrease of acidity and the increase of ethanol concentration. This clearly explains why the recovery of the dye from a cartridge using 95% v/v ethanol led to rapid color-fading of the dye. For this reason, in a later section when the dye was to be recovered from a cartridge, an eluent containing both ethanol and acid was used. The concentration of ethanol in the eluent should be no more than 40% v/v.

Desorption

The desorption test was made on a series of cartridge previously loaded with 1 μmol of the pink azo dye (a 100 mL of 10 μM nitrite and 8 mL of reagents). The elution was made by a mixture of dilute HCl (60 mM) and various concentrations of ethanol at a flow rate of ca. 5 mL min^{-1} . It was found that the recovery of the dye was incomplete if the ethanol concentration was lower than 23% v/v, but it was completed when higher

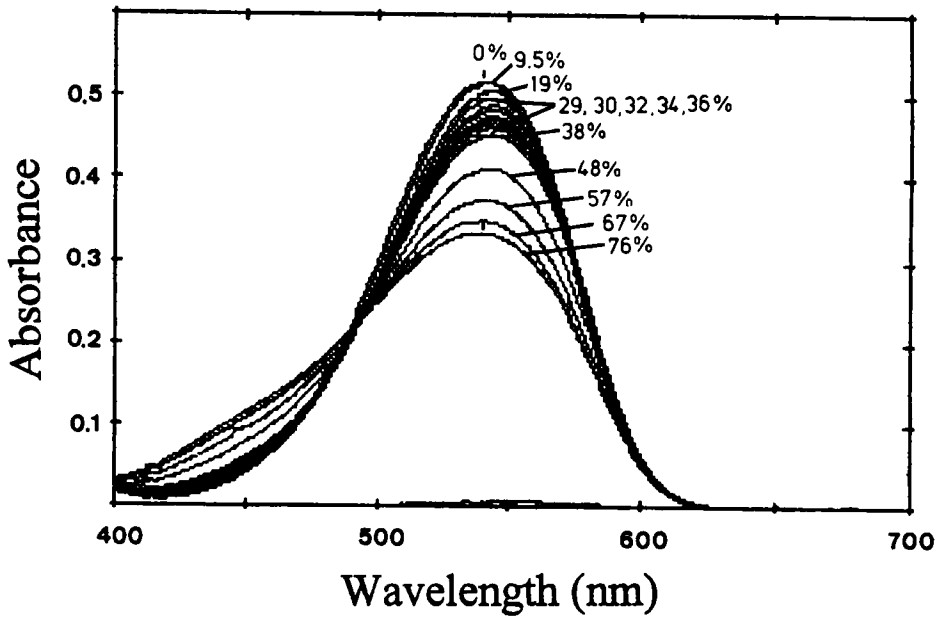

Figure 3 Effect of ethanol concentration (as % v/v) to the absorption spectrum of the pink azo dye. All sample contained 10 μM nitrite and the final acidities were fixed at 34 mM.

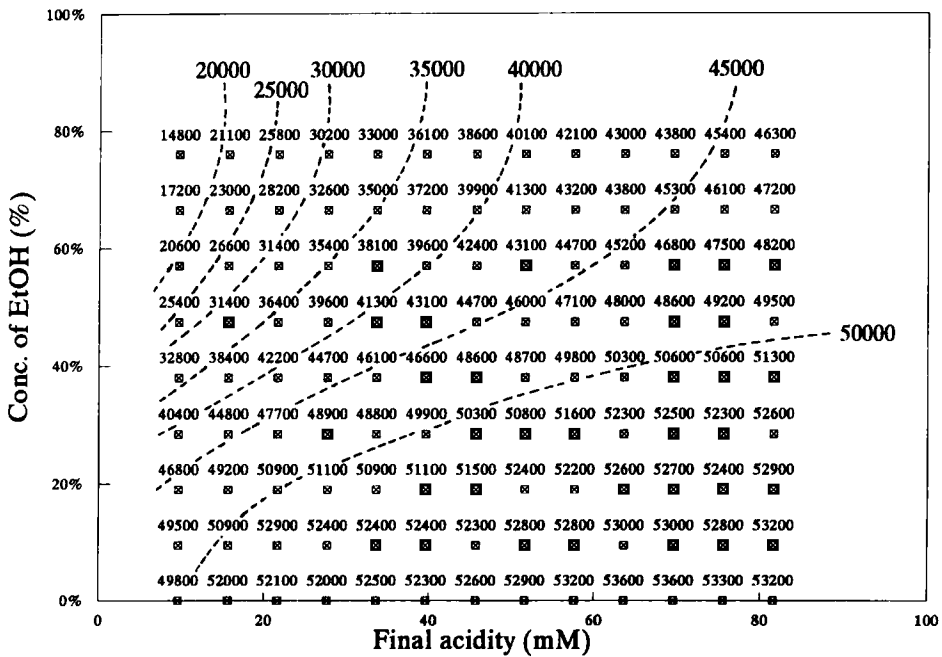

Figure 4 Contour plot of the molar extinction coefficient ($\text{M}^{-1}\text{cm}^{-1}$) of pink azo dye at various acidities and ethanol concentrations.

than 28% v/v. Accordingly, a combination of 60 mM HCl + 38% v/v ethanol was recommended for the elution. Using this condition, the molar extinction coefficient of the pink azo dye in the final yield was very close to $5.00 \times 10^4 \text{ M}^{-1}\text{cm}^{-1}$ (also see Figure 4). The color in this solution could be stable for ca. 1 hr, but it was faded gradually following an exponentially decay trend ($A = A_0 \times e^{-kt}$). At room temperature the decay constant k was 0.0086 hr^{-1} , indicating a "half-life time" of ca. 80 hrs. Therefore the measurement should be carried out within 1 hour after the dye was recovered from the cartridge.

Breakthrough test

In the breakthrough test both Milli-Q water and a filtered seawater sample were used. After reagents were added, the spiking concentrations accounted for the pink azo dye were 0.93, 9.3 and 18.5 μM respectively. The breakthrough curve for each solution was performed at three different flow rates, i.e. 9, 18, and 27 mL min^{-1} , and the curves obtained on the recorder chart (in time scale) are shown in Figure 5 (left). These curves were re-drawn by converting the coordinate to volume scale and are also shown in Figure 5 (right). It can be seen that, on the volume scale, the adsorption efficiency of the cartridge was strongly related to the ionic strength of the medium, but was likely to be independent of the flow rate within the tested range. In general, the V_b values for seawater were nearly four times larger than those for the freshwater samples at the same conditions (Table 1). The adsorption seemed to have little influence on the concentration. It is clear that the sample volume is a critical parameter in controlling the analytical loss. The extent of loss of the analyte can be estimated by integrating of the area beneath the breakthrough curve along the volume-axis, and then comparing with the area calculated by multiplying the volume and the initial absorbance. For instance, the maximum sample volume for no more than 2% loss at 1 μM level was 500 mL for the freshwater sample, whereas it was 1.5 L for seawater sample.

Reagent blank

The blank test was carried out by passing various volumes of Milli-Q water (added with 4% v/v of each reagent) through the cartridge and collecting the eluate for the measurement. The results are shown in Table 2. The readings increased proportionately with the volume of the sample and reagents passed when the size of the sample was less than 500 mL. Above this threshold the increase of reading became non-linear with the sample volume, as loss of analyte occurred. The reading for a 500 mL aliquot of Milli-Q water plus 40 mL of reagents was 0.005. However, the sources for which the contaminant was introduced could not distinguished if the Milli-Q water and the reagents were mixed in proportion. A further examination on this problem was carried out by adding various amounts of reagents to the same volume (500 mL) of Milli-Q water. It was found that when the amount of reagents was doubled the increment of reading was only 0.002. Therefore only 40% of the blank reading should be accounted for the "net" reagent blank, whereas the rest 60% of the blank reading should attribute to the contaminant in the Milli-Q water. Accordingly, the concentration of nitrite in the Milli-Q water was estimated to be ca. 1.2 nM.

Since the adsorption behavior in seawater was different from that in freshwater, the reagent blank for seawater having a volume larger than 500 mL could not be identified

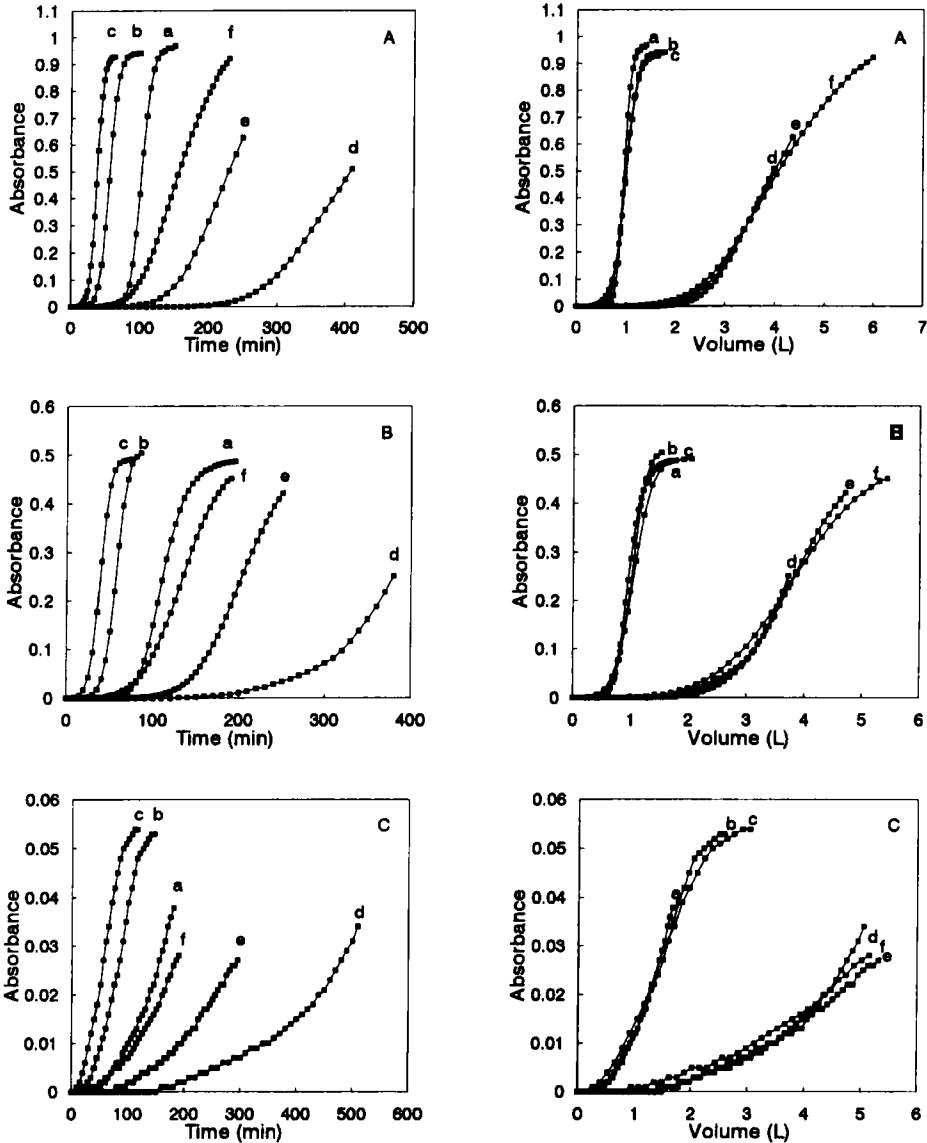

Figure 5 Breakthrough curves made by passing the pink azo dye solutions through the Sep-Pak C_{18} cartridge at various flow rates. The diagrams shown on the left are plotted on the time scale; after being re-drawn on the volume scale they are shown on the right.

Concentration: (A) $18.5 \mu\text{M}$; (B) $9.3 \mu\text{M}$; (C) $0.93 \mu\text{M}$. Medium: (a), (b), (c) freshwater; (d), (e), (f) seawater. Flow rate: (a), (d) 9 mLmin^{-1} ; (b), (e) 18 mLmin^{-1} ; (c), (f) 27 mLmin^{-1} .

directly. An alternative way was to subtract an equivalent reading from the raw absorbance. For example, the equivalent reagent blank readings of 0.002, 0.004, and 0.006 were accounted for 500 mL, 1 L, and 1.5 L sizes of seawater sample in this experiment.

Table 1 Volume of half-concentration breakthrough estimated from Figure 5.

Conc. (μM)	V_h (L) measured at different flow rates (mL/min)		
	9	18	27
	<i>(in freshwater)</i>		
0.93	1.40	1.46	1.42
9.30	0.96	1.01	1.04
18.50	0.95	0.97	0.99
	<i>(in seawater)</i>		
0.93	4.80	5.30	5.10
9.30	3.68	3.78	3.80
18.50	3.85	3.88	3.95

Table 2 Test of reagent blank for various volumes of Milli-Q water and reagents.

Volume of Milli-Q water (mL)	Volume of reagents added (mL)	Reagent ratio (v/v)	Absorbance for 10 mL of the final yield				
			i	ii	iii	Mean	\pm sd
100	8	8%	0.001	0.002	0.001	0.001	0.0005
250	20	8%	0.003	0.003	0.002	0.003	0.0005
500	40	8%	0.005	0.005	0.006	0.005	0.0005
750	60	8%	0.008	0.007	0.007	0.007	0.0005
1000	80	8%	0.009	0.009	0.009	0.009	0.0000
1500	120	8%	0.013	0.012	0.013	0.013	0.0005
2000	160	8%	0.015	0.015	0.016	0.015	0.0005
500	40	8%	0.005	0.005	0.005	0.005	0.0000
500	80	16%	0.007	0.007	0.008	0.007	0.0005
500	120	24%	0.009	0.009	0.008	0.009	0.0005

The reading of 0.005 for 500 mL of Milli-Q water plus 40 mL of reagents equivalents to 1 nmol of nitrite. Calculation shows that approximately 40% of this amount was introduced by the reagents. The concentration of contaminant in the Milli-Q water used was ca. 1.2 nM.

Sample size and recovery

Known amounts of nitrite were added to various sizes of Milli-Q water and of a filtered surface seawater to give spiking concentrations of 20 and 100 nM. The spiked samples were pre-concentrated and recovered by the proposed manual procedure. After correction for the initial concentrations, the recoveries were plotted against sample volume in Figure 6. These results agreed well with the findings obtained from the former breakthrough experiment at higher nitrite concentrations (1–20 μM). In freshwater the recovery was almost quantitative when the sample volume did not exceed 250 mL, and was ca. 98% for 500 mL, ca. 94% for 1 L, and ca. 66% for 2 L. In seawater the corresponding recoveries were higher, to be 100% for the sample volume of less than 500 mL, 99% for 1 L, ca. 98% for 1.5 L, and ca. 94% for 2 L respectively.

Precision

The precision of the manual procedure was tested on the Milli-Q water and a filtered coastal seawater after they were spiked with known amounts of nitrite. All the

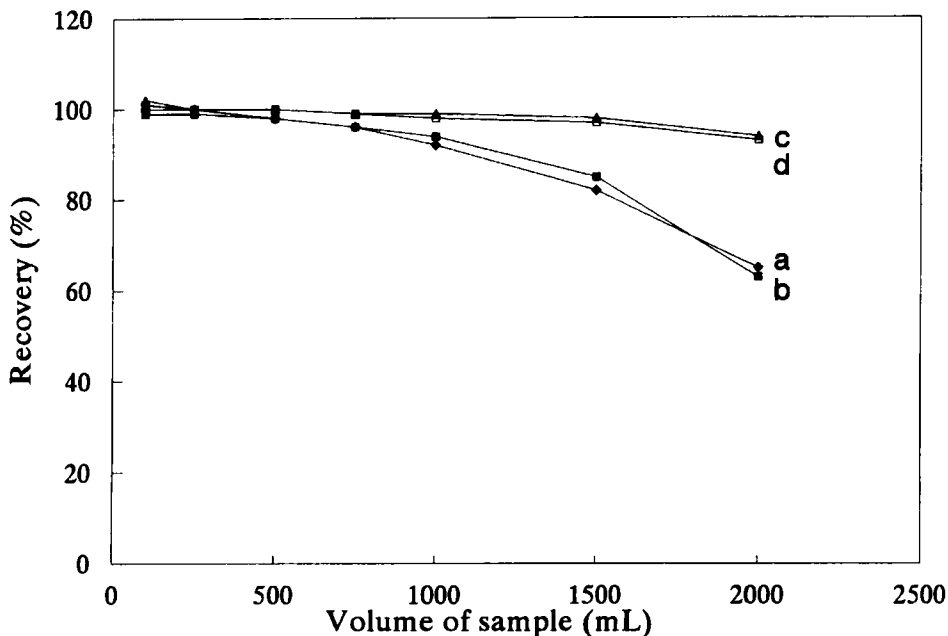

Figure 6 Recovery of the spiked pink azo dye from the Sep-Pak C_{18} cartridge as a function of the sample volume. (a) 18.5 nM (b) 93 nM spiked in freshwater; (c) 18.5 nM (d) 93 nM spiked in seawater.

measurements were triplicated and the results are shown in Table 3. For samples containing 20–80 nM of nitrite the relative standard deviations (RSD) were generally less than 2%. The precision was no more than 1% RSD when the sample volume was 1.5 L.

Detection limit

The detection limit was estimated by taking account of three folds of the standard deviation of the reagent blank, and dividing it by the concentration factor. In Table 2 the standard deviations of the blank readings for Milli-Q water sample were ca. 0.0005. This corresponds to a detection limit of ca. 0.6 nM, if a concentration factor of 50 folds applies; and it could be further lowered to 0.3 nM or less if the concentration factor were over 100 folds.

Storage of pre-loaded cartridge

Aliquots of 500 mL of Milli-Q water and a filtered coastal seawater was spiked with 80 nM of nitrite. After adding reagents, they were loaded separately onto a series of the Sep-Pak C_{18} cartridges. These loaded cartridges were wrapped with a layer of polyethylene film to prevent the resin from going dry, and then stored in a dark place at room temperature.

Recovery of the dye was carried out separately on the 2nd, 4th, 7th, and 9th day. The final yield was measured immediately after the elution, and the resultant absorbances are

Table 3 Precision test on nitrite—spiked samples using the proposed manual procedure.

Medium	Volume (mL)	[NO ₂ ⁻] spiked (nM)	Raw absorbance			Mean	RSD	[NO ₂ ⁻] found* (nM)
			(i)	(ii)	(iii)			
Milli-Q water	500	0	0.006	0.005	0.005	0.005	8.8%	1.3
	500	8	0.026	0.024	0.026	0.025	3.7%	9.3
	500	20	0.057	0.058	0.056	0.057	1.4%	22.0
	500	40	0.107	0.103	0.105	0.105	1.6%	41.2
	500	80	0.208	0.202	0.203	0.204	1.3%	80.9
Seawater	1000	0	0.113	0.111	0.108	0.111	1.9%	21.3
	1000	10	0.167	0.163	0.159	0.163	2.0%	31.8
	1000	20	0.214	0.216	0.213	0.214	0.6%	42.1
	1000	40	0.312	0.305	0.307	0.308	1.0%	60.8
	1500	0	0.164	0.164	0.166	0.165	0.6%	21.2
	1500	20	0.318	0.313	0.320	0.317	0.9%	41.5
	1500	40	0.467	0.467	0.471	0.468	0.4%	61.6

All samples were added with 4% (v/v) of each reagent, and the final volumes were 10.0 mL. *Concentration was calculated from Eq.(1). Reagent blank readings of 0.002, 0.004, and 0.006 were accounted for 500 mL, 1 L, and 1.5 L sizes of sample respectively.

listed in Table 4. In freshwater media, the cartridge-bound pink azo dye was quite stable in the first two days, but its absorbance reading dropped by 1.5% after 4 days, 3.5% after 7 days, and 7% after 9 days. In seawater medium the bound pink azo dye was apparently more stable. The absorbance for the recovered dye decreased by 0.5%, 2%, and 3.5% after storing for 4, 7, and 9 days respectively.

Cycling loop system

The manual procedure, although so easy to be carried out in a land-based laboratory, is unlikely suitable to be performed on-board a ship. The maneuvering of the volumetric adjustment to a final 10.0 mL, the transferring of the final yield to a standard cuvette, and

Table 4 Stability of pink azo dye bound to the Sep-Pak C₁₈ cartridge.

Storage time (day)	Absorbance of the 10 mL final yield	
	Spiked Milli-Q water	Spiked seawater
0	0.206	0.236
2	0.205	0.236
4	0.203	0.235
7	0.199	0.232
9	0.191	0.228

Aliquots of 500 mL of Milli-Q water and seawater were spiked with 80 nM of nitrite. After mixed with reagents, they were loaded on a series of the Sep-Pak C₁₈ cartridge, and then stored in a dark place at room temperature. The measurements of the recovered dye were made on separate days.

the washing of the flasks are all troublesome in a ship laboratory. With the cycling loop system (Figure 2) these difficulties could be avoided. The final volume in the loop was fixed, and the detection was made directly with the on-line flow cuvette which ceased the need of transferring the sample. Furthermore, the loading of the sample, the injection of eluent to desorb the dye, and the regeneration of the cartridge could all be done on the same system by simply turning the control valves.

When ethanol eluent was injected in to the loop, the desorption started as it passed through the cartridge. The number of the recycling could be monitored on the display screen (see Figure 7 for demonstration). In the first cycle the desorbed pink azo dye gave a sharp peak when it passed through the detector. This first peak could not be used for quantification, because the non-continuous boundary between alcohol and water gave rise to refractive index interference. As the liquid in the loop ran for more than 15 cycles, the concentration became gradually homogeneous and finally the signal reached a steady-state. At this stage the refractive index interference was eliminated completely, and the final reading was taken. It was noticed that a small fraction of the dye was re-adsorbed onto the resin to cause the reading to be lower than expected. This re-adsorption phenomenon did not affect the quantification because the calibration was made by running standards at the same conditions. It was also noticed that small bubbles might form occasionally in the closed loop, probably due to the mixing of the alcohol with water. By using a large-window flow cuvette (capacity 450 μL), those bubbles when passing through the detector would only give a fluctuated signal and therefore did not affect the final reading.

Nitrite spiked samples were tested on the proposed-cycling loop system. The calibration curves made for 500 mL Milli-Q water and 1 L seawater are shown in Figure 8. The slopes were 0.0049 and 0.0089 A.U. nM^{-1} respectively. These sensitivities were almost doubled compared to that obtained by the manual procedure (0.0025 and 0.0050 A.U. nM^{-1}), as the final volume in the loop was 4.23 mL instead of 10 mL.

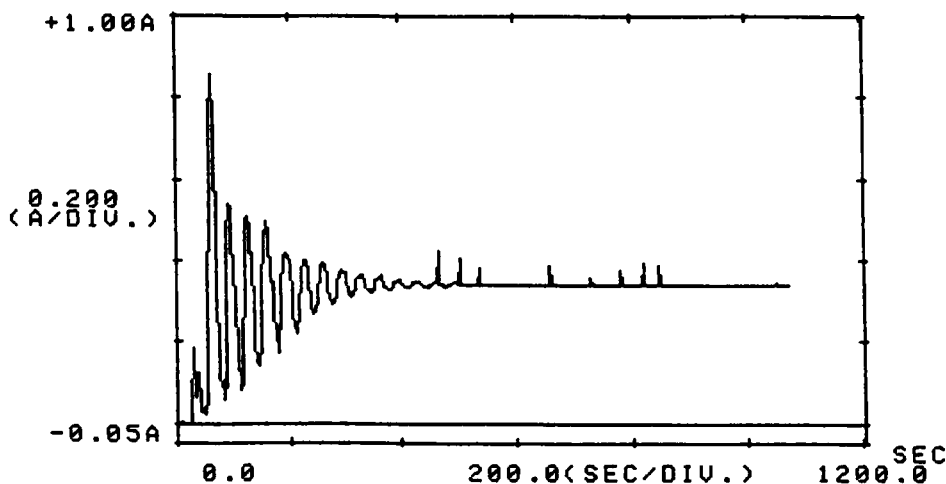

Figure 7 Typical signal output (on the screen of the Shimadzu 160A spectrophotometer) produced by the automated cycling loop system shown in Figure 2. A 1 L-aliquot of a filtered surface seawater sample (mixed with 80 mL of reagents) was loaded previously. The dye was desorbed and re-cycled in the loop (with a final volume of 4.23 mL) at a flow rate of 10 mLmin^{-1} . The concentration of nitrite in this sample was estimated to be 37.5 nM.

However, at equilibrium ca. 17% of the dye was bound to the cartridge in the freshwater medium. The extent of re-adsorption was high (ca. 25%) for the seawater sample. As a result, the quantification should be referred to the calibration curves made by the standard addition technique, and the reagent blank needed to be evaluated separately in a manual way.

The nitrite content in several water samples were examined by both the cycling loop system and the manual procedure. The results from both methods agreed well and are shown in Table 5.

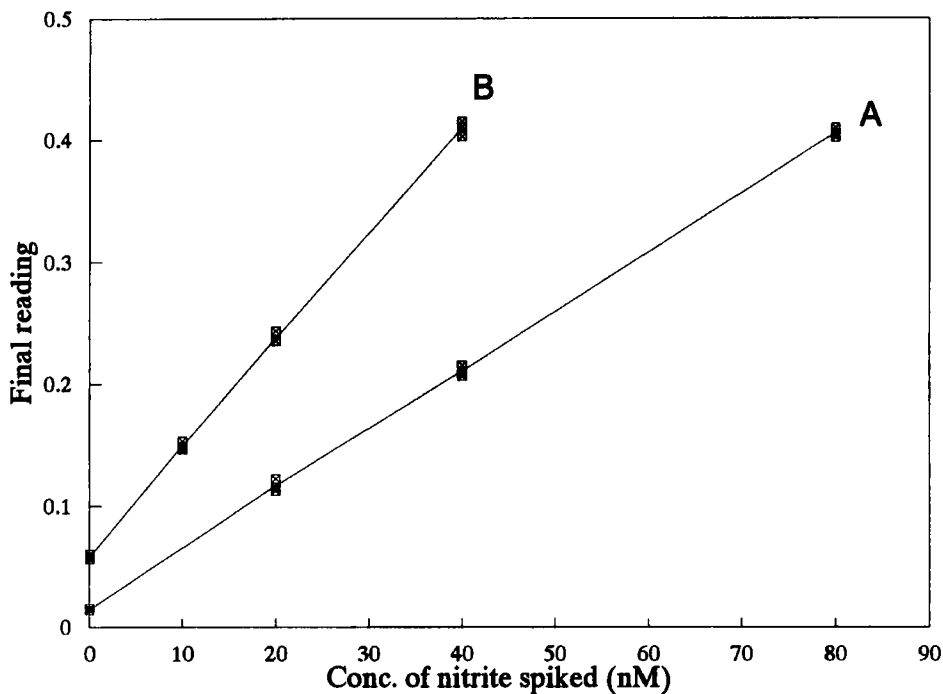

Figure 8 Calibration curves made for (A) 500 mL-aliquot of Milli-Q water and (B) 1 L-aliquot of seawater, using the proposed cycling loop system. Each sample was measured in triplicate.

Table 5 Comparison on the results obtained by the proposed manual and loop procedures.

Sample	Volume used (mL)	Manual procedure (nM)	Loop procedure (nM)
Distilled water	500 mL	12.5 ± 0.3	12.9 ± 0.5
Rain water A	200 mL	345 ± 4	347 ± 5
Rain water B	200 mL	443 ± 3	437 ± 5
Lake water	500 mL	187 ± 1	189 ± 2
Seawater A	1000 mL	22.4 ± 0.3	23.1 ± 0.5
Seawater B	1000 mL	67.5 ± 0.3	67.0 ± 1.7

Each sample was measured in triplicate.

CONCLUSIONS

The accurate and precise determination of trace amounts of nitrite has always been a difficult task to the environmental analysts, not only due to the low concentration of nitrite present but also due to its unstable characteristics. The content of nitrite in a sample bottle may be changed quickly as a result of the bacterial activities. With conventional methods the measurement should be carried out promptly after the sample collection⁷. No preservatives have been found completely satisfactory. However, if nitrite can be fixed as pink azo dye and then adsorbed onto a Sep-Pak C₁₈ cartridge, it can be stable for a period of up to 4 days with minimal change. This would be advantageous to field workers, because one may pre-concentrate nitrite as dye at the sampling site and bring only the cartridges back to the laboratory for further analysis.

The Sep-Pak C₁₈ solid extraction technique has been proven very efficient to adsorb pink azo dye from both freshwater and seawater, and the analytical details of recovering the dye for the measurement have been demonstrated. The proposed manual procedure, although very simple, provides a very high sensitivity and a good precision to measure nM levels of nitrite in natural waters. Comparing with other miscellaneous techniques, it has the advantages in terms of easy-handling, reliability, and low cost.

The proposed manual method has also been automated by a cycling loop system to suit ship-board operation. The maneuvering has been largely minimized, and the sensitivity has been found higher than that of the manual procedure. However, since the loading and the recycling processes are still time-consuming, the throughput rate is currently limited to 1 sample per hr. Further improvements to reduce the loop volume will be commenced. This would also help to reduce the sample size and hence to shorten the analysis time.

This technique has the potentiality to be further applied to the determination of trace levels of nitrate/ammonia in natural waters including surface seawater, after the sample being previously treated with a reduction/oxidation process to convert them to nitrite.

Acknowledgements

The authors would like to thank Ethel Pai for her criticism on the manuscript. This study was sponsored by the National Science Council, Taipei, Taiwan under the contract number NSC-82-0208-M002A-028.

References

1. G. Garside, *Deep-Sea Res.*, **32**, 723–732 (1985).
2. K. Bendschneider and R. J. Robinson, *J. Mar. Res.*, **11**, 87–96 (1952).
3. J.D.H. Strickland and T. R. Parsons, In: *A Practical Handbook of Seawater Analysis* (Fisheries Research Board of Canada, Ottawa, 1972).
4. G. Garside, *Mar. Chem.*, **11**, 159–167 (1982).
5. In: *Waters Sep-Pak Cartridge Care and Use Manual*, (Waters Chromatography Publications, PN011188, Rev. 5, 1992).
6. S. C. Pai, C. C. Yang and J. P. Riley, *Anal. Chim. Acta*, **232**, 345–349 (1990).
7. In: *APHA Standard Methods for the Examination of Water and Wastewater*, (American Public Health Association, Washington DC, U.S.A. 16th ed., 1985).