

## Transform domain adaptive enhancement filter for evoked potential

Bor-Shyh Lin<sup>1</sup>, Bor-Shing Lin<sup>1</sup>, Jen-Chien Chien<sup>1</sup>, Fok-Ching Chong<sup>1</sup>, Yue-Der Lin<sup>2</sup>

<sup>1</sup> Institute of Electrical Engineer, National Taiwan University, Taiwan R.O.C.

<sup>2</sup> Post-Baccalaureate School of Chinese Medicine China Medical College, Taiwan R.O.C.

**Abstract** - This paper is to present the use of transform domain adaptive filter (TDADF) to process evoked potential (EP). The use of adaptive filter (ADF) in processing EP is effective than traditional averaging method. However to design an ADF with normalized LMS with good convergence performance is not an easy task. Thus, we proposed the TDADF method to improve the convergence performance of processing EP. Simulations were conducted to obtain the SNR of visual evoked potential. Moreover, collected data from somatosensory evoked potential was used in the testing. We observed that TDADF method has better performance than ADF with normalized LMS algorithm.

**Keywords** - Evoked potential, Transform domain adaptive filter

### I. INTRODUCTION

Evoked potential is an important parameter in brain neural domain. However EP is a weak signal and is always embedded in electroencephalogram (EEG). Thus, the common traditional practise of obtaining EP is by ensemble averaging method. Since the advance of digital signal processing, many new methods are used to replace the traditional method. Of these, the ADF method is a significant better method.

We have used adaptive signal enhancement filter with normalized LMS (NLMS) to process EP [1]. For only 50 EP data collected, we were able to obtain a satisfactory result for SNR of -30 db. In NLMS adaptive filter, to get better performance, a smaller adaptive step size and multiple filter taps are favorable. However, this approach may lead to longer convergence time. Thus, in order to obtain a fast and good convergence effect, TDADF structure with NLMS to process EP is a better solution.

### II. METHODOLOGY

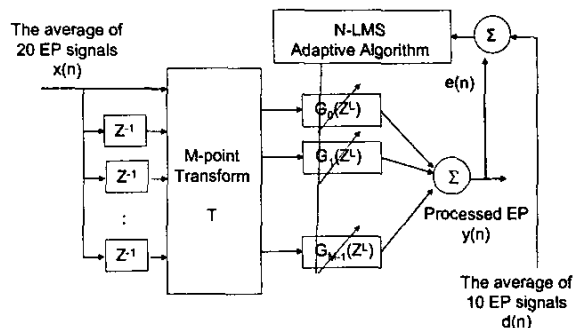

Fig.1. The structure of transform domain adaptive filter for EP

As shown in Fig.1. The structure of transform domain adaptive filter is a sub-band filter [2]. Before the input signal  $x(n)$ , the average of 20 precoded EP signals, is input to the adaptive filter for processing, this signal is transform to another transform domain. The convergence of ADF with gradient type algorithm is correlated with the Auto-correlation matrix of input signal. When the spread space of these attribute values is small, the input signal is closer to white noise, the algorithm exhibits faster convergence speed. Thus it is possible to minimize the eigen value spread by T matrix transformation of the input autocorrelation matrix. In this paper, Walsh-Hadamard transform (WHT) [3] is used. After transformation the eigen values are group into M-point outputs. These outputs are adaptively processed by M stages of sub-band adaptive filters. NLMS algorithm is used in these adaptive stages.

### III. RESULTS

Data collected from somatosensory evoked potential (SEP) is used in this simulation. First, a set of 4000 data of SEP was processed using averaging method and was

designed as the standard pattern. Then, this set was mixed with EEG signal to obtain a -30db EP composite signal.

Using this EP composite signal as input, the results after obtained processing through the structure were checked with standard pattern. Table I tabulated the results of ADF and TDADF in different combination of adaptive filter taps N and adaptive step size  $\mu$ . In table I, as the adaptive filter taps increases, there is significant decrease in mean square error (MSE) for TDADF with NLMS, but these is practically no change in MSE for ADF with NLMS. The reason is that the attribute values spread of TDADF is preprocess prior to changes in adaptive filter taps. Thus, the TDADF has better convergence result that ADF.

Following, the SNR response for both structures were investigated using  $SNR_{ml}$  and  $SNR_r$  [4][5]. In Table II, when the filter taps is increased and the adaptive step size is decreased, the SNR value of TDADF showed good result. This implied that changes in filter taps and step sizes will effect the SNR of TDADF. However, this outcome is not significant in ADF.

TABLE I Mean Square Error of EP processing with ADF and TDADF

Filter Taps	Step Size	Mean Square Error	
		ADF	TDADF
N=8	$\mu=0.05$	0.0829	0.0797
	$\mu=0.1$	0.0805	0.0792
	$\mu=0.5$	0.0787	0.0870
N=16	$\mu=0.05$	0.0790	0.0691
	$\mu=0.1$	0.0776	0.0720
	$\mu=0.5$	0.0787	0.1026
N=32	$\mu=0.05$	0.0751	0.0669
	$\mu=0.1$	0.0746	0.0700
	$\mu=0.5$	0.0778	0.1169

TABLE II Signal Noise Ratio of EP processing with ADF and TDADF

Filter Taps	Step Size	$SNR_{ml}$		$SNR_r$	
		ADF	TDADF	ADF	TDADF
8	0.05	2.4056	4.0638	2.4093	4.0893
	0.1	4.0256	4.0113	4.0419	4.0358

	0.5	4.4347	1.6632	4.4798	1.6928
16	0.05	4.0579	4.1394	4.0788	4.1836
	0.1	5.5410	3.6002	5.5905	3.6949
	0.5	3.5667	1.1186	3.6206	1.1653
32	0.05	4.6119	5.9534	4.6418	6.1224
	0.1	4.7463	4.3665	4.7960	4.5913
	0.5	2.3603	0.9400	2.4122	1.1093

#### IV. CONCLUSION

The result clearly showed that the TDADF structure with greater filter taps and smaller step size is a good choice. The use of WHT in processing attribute of autocorrelation matrix will increase convergence speed. It setback is that its convergence effect is more sensitive to step size. In spite of this, TDADF is a considerable good tool in EP approach.

#### REFERENCE

- [1]B.S.Lin,etc., "Estimation Of Evoked Potentials Using High Order Statistics-Based Adaptive Filter", 23rd Annual International Conference of the IEEE Engineering in Medicine and Biology Society, 2001.
- [2]Mariane R. Petraglia,etc., "Adaptive FIR Filter Structure Based on the Generalized Subband Decomposition of FIR Filter", IEEE Trans. On Circuit and System, vol.40, 1993, p354-362.
- [3]A.Mahalanobis,etc., "Adaptive FIR Filters Based On Structural Subband Decomposition for System Identification Problems", IEEE Trans. On Circuit and System, vol.40, 1993, p375-381.
- [4]R.Coppola,etc., "Signal to noise ration and response variability measurements in single trial evoked potentials", Electroencephlogr. Clin. Neurophysiol., vol.44,1978, p214-218.
- [5]N.J. Bershad,etc., "On estimating signal-to-noise ratio using the sample correlation coefficient", IEEE trans. On Info. Theory, vol.20,1974, p112.