

A 38-48-GHz Miniature MMIC Subharmonic Mixer

Wei-Chien Chen, Shih-Yu Chen, Jeng-Han Tsai, Tian-Wei Huang, and Huei Wang

Department of Electrical Engineering and Graduate Institute of Communication Engineering,
National Taiwan University, Taipei, Taiwan 106, R.O.C.
Email: twhuang@cc.ee.ntu.edu.tw

Abstract — a 38-48-GHz miniature sub-harmonically pumped mixer has been developed using GaAs 0.15- μm pHEMT technology. An anti-parallel diodes pair is used for frequency conversion with a low LO input power. Quasi-lumped matching topology is employed to minimize the chip size and cost. The mixer is fabricated in chip size $0.85 \times 0.85 \text{ mm}^2$, and exhibit 12-15-dB up-conversion loss and 11-16-dB down-conversion loss with 10 dBm LO power.

I. INTRODUCTION

For years, millimeter-wave equipments and circuits have been studied and utilized for satellite communication systems and high-speed data communication systems [1]. In these systems, reduction of cost and power consumption is much desired.

Mixers play a key role in the communication systems. They provide primary frequency conversion from radio-frequency band to intermediate-frequency band in all sorts of transceivers. Passive mixers have zero DC power consumption, which include diode mixers and resistive mixers [2], [3]. Anti-parallel and ring-quad topologies [4]-[6] have been used most commonly for diode mixers, especially for sub-harmonically pumped mixer.

Subharmonic mixers offer an alternative to fundamental mixers in that LO frequency is at half of the fundamental LO frequency. Due to the use of a LO at relatively low frequency, the output power and phase noise performance may be superior to the fundamental LO source. Moreover, the subharmonic mixers have better LO to RF isolation than that of the fundamental ones.

So far, the fabricated mixers can operate at very broad frequency ranges with good conversion loss; however, they either occupy large chip area or require large LO input power [4]-[9]. In [10], a quasi-lumped matching topology is used to reduce the size of quarter-wavelength open/short stub for uniplanar design in microwave frequencies. In this paper, we apply the quasi-lumped topology to millimeter-wave frequencies, and use microstrip lines for miniature circuit implementations. Adopting anti-parallel diode pair lower the LO input power requirements. Furthermore, it requires no dc power, and can be used for both up- and down-conversion.

II. TECHNOLOGY

This circuit was fabricated with 0.15- μm GaAs HEMT MMIC process on 100- μm GaAs substrate provided by WIN Semiconductors. The unit current gain frequency (f_T) of the device is about 85 GHz, and the maximum oscillation frequency (f_{max}) is over 200 GHz. Typical breakdown voltage is 10V and the peak of transconductance (G_m) is 495 mS/mm. Other passive components such as thin-film resistors, MIM capacitors, spiral inductors, and air-bridges are available. The 6" wafer is thinned down to 4-mil for the gold plating of the backside, and slot via holes are used for dc grounding [11].

III. CIRCUIT DESIGN

The schematic of the mixer is shown in Fig.1. The anti-parallel pair is chosen as the mixing core and each diode has total gate width 30 μm (2f15). A couple-line RF bandpass filter is utilized to avoid noise at RF port and increase isolation among RF-LO and RF-IF. Besides, there are three stubs used for isolation consideration: $\lambda_{\text{LO}}/4$ open stub and $\lambda_{\text{LO}}/4$ short stub isolate RF port from LO port, while $\lambda_{\text{RF}}/4$ open stub isolate IF port from RF.

However, the quarter-wave transmission lines are too long and occupy too much area. By applying quasi-lumped method, each stub is shortened. Quasi-lumped ones, as shown in Fig.2, replace the $\lambda_{\text{LO}}/4$ and $\lambda_{\text{RF}}/4$ open stubs. The capacitances, C1 and C2, and electrical length θ of the quasi-lumped open stub are determined in [10].

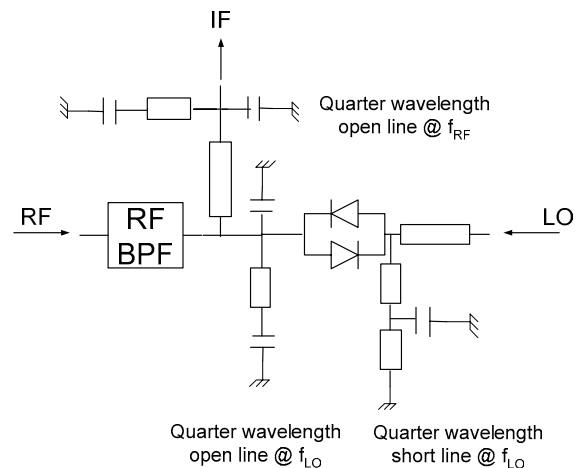

Fig. 1. Schematic of the subharmonic mixer.

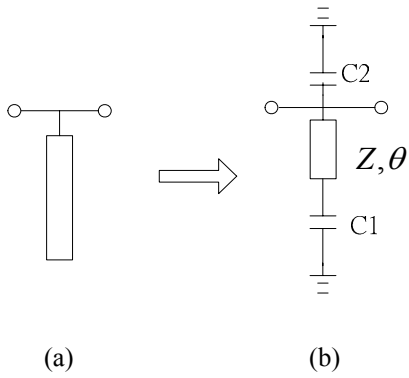

Fig. 2. (a) $\lambda/4$ open stub (b) quasi-lumped $\lambda/4$ open stub

On the other hand, the quasi-lumped short stub is substituted for $\lambda_{LO}/4$ short stub, as shown in Fig. 3. The capacitance C_s , and electrical length θ_1 , θ_2 are determined in [10]. Consequently, the chip size is reduced to $0.85 \times 0.85 \text{ mm}^2$, as shown in Fig.4. All the simulations are based on AWR's [12] Microwave Office software and Sonnet Software [13].

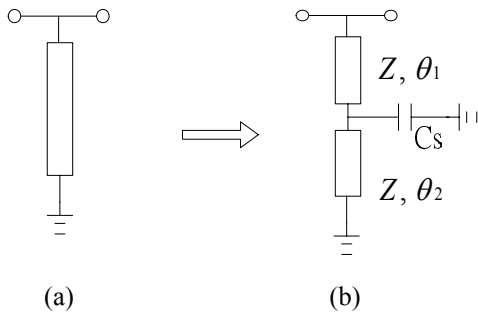

Fig. 3. (a) $\lambda/4$ short stub (b) quasi-lumped $\lambda/4$ short stub

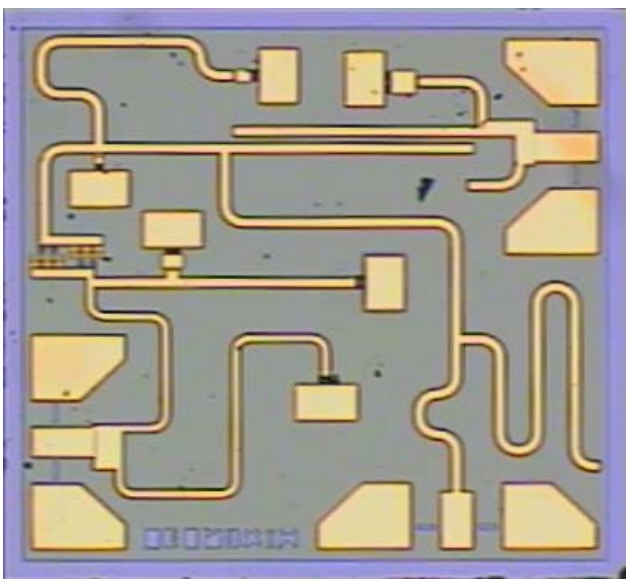

Fig. 4. Photograph of the SHP mixer chip.

IV. MEASURED PERFORMANCE

The mixer was measured with on-wafer probing. We used Agilent E8247C PSG as a local oscillator (LO), another Agilent E8247C PSG as a baseband to intermediate frequency (IF) signal generator, and Agilent E4448A PSA as the spectrum analyzer. The measurement setup is shown in Fig. 5.

All connections to the chip are made using coplanar probes. The RF is applied through a W-band air coplanar probe with 1.2-dB loss, and the intermediate frequency (IF) is extracted using a 0-50GHz coplanar probe, which has 1-dB loss.

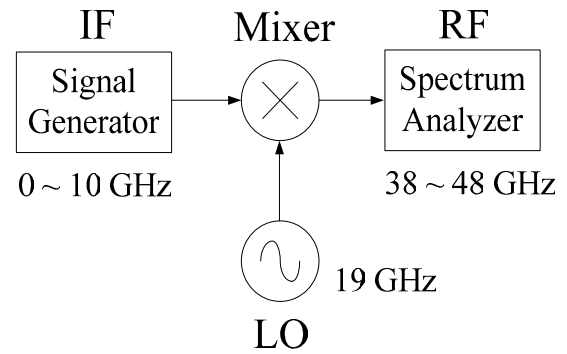

Fig. 5. measurement setup for the mixer in millimeter wave frequency.

Measured up-conversion and down-conversion characteristics are plotted in Fig.6 through Fig.10.

To get best conversion loss, as shown in Fig. 6, a LO drive power of 10 dBm was used for the measurements. While the IF frequency is swept from 0 to 10GHz, the mixer exhibits an up-conversion loss of 12 to 15 dB in Fig. 6, the LO-to-RF and 2LO-to-RF isolation is more than 29dB in Fig. 7.

Additionally, the mixer also presents a down-conversion loss of 11-16dB in Fig. 8, the LO-to-IF isolation is more than 17 dB, and the 2LO-to-IF isolation is better than 55 dB in Fig. 9, as RF frequency is swept from 38 to 48 GHz.

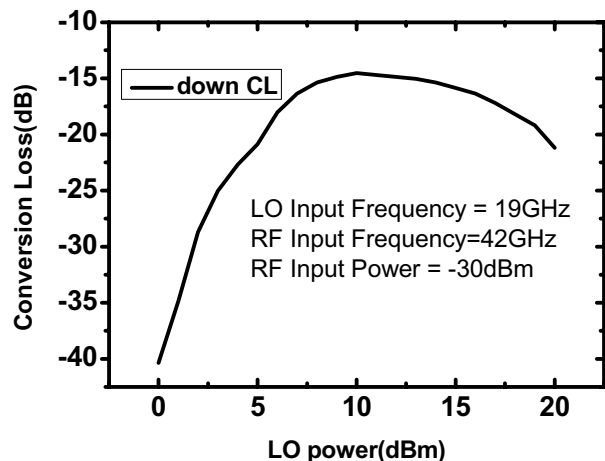

Fig. 6. LO power versus conversion loss.

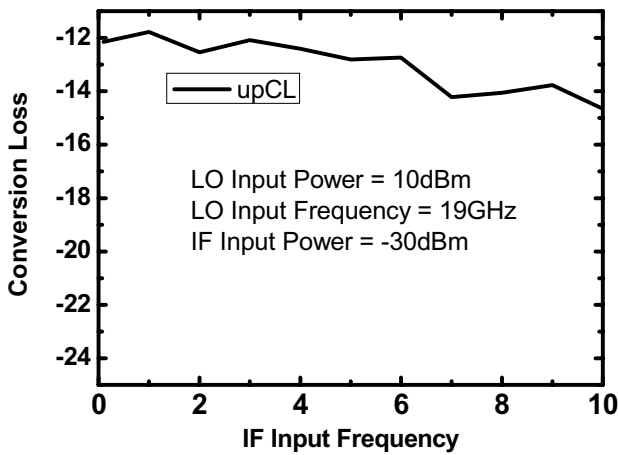

Fig. 7. Up-conversion loss of the SHP mixer.

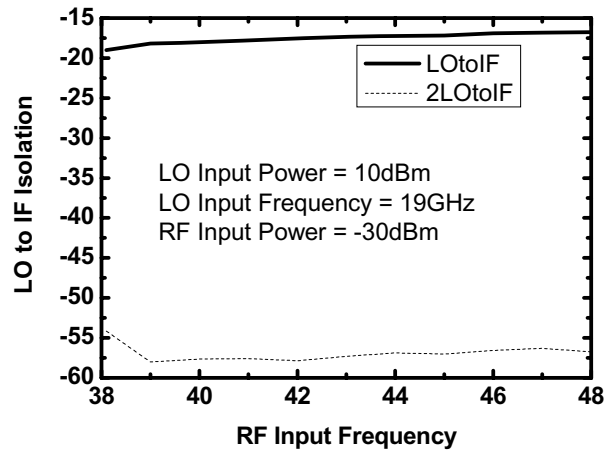

Fig. 10. LO-IF isolation of the SHP mixer.

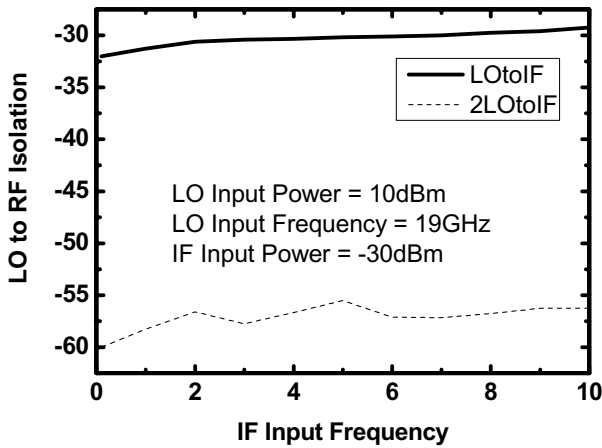

Fig. 8. LO-RF isolation of the SHP mixer.

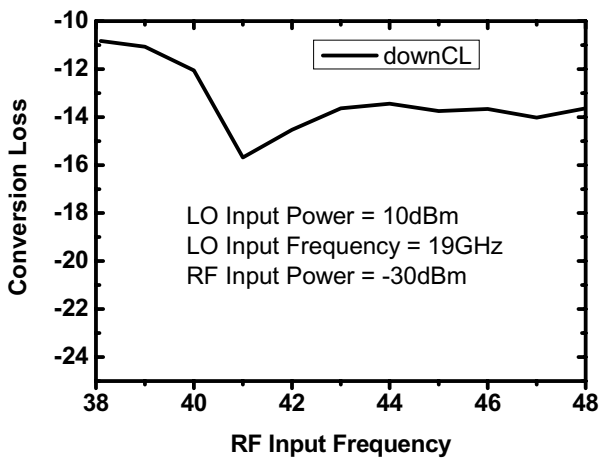

Fig. 9. Down-conversion loss of the SHP mixer.

V. CONCLUSION

This paper presents a 38-48-GHz miniature subharmonically pumped mixer with low LO input power, 10dBm. The mixer exhibits an up-conversion loss of 12 to 15dB, and the LO-to-RF isolation is more than 29dB; besides, the down-conversion loss is 11-16dB, and the LO-to-IF isolation is more than 17dB. In addition, the quasi-lumped topology minimizes the chip size and cost.

ACKNOWLEDGEMENT

The work was supported in part by National Science Council (NSC 93-2219-E-002-025 and NSC 92-2220-E-002-005). The MMIC chip is fabricated by WIN Semiconductors through the Chip Implementation Center (CIC), Taiwan, R.O.C. The authors would like to thank Yi-Lin Lee and Shih-Fong Chao for their assistance on chip measurements.

REFERENCES

- [1] Y. Takimoto, "Research activities on millimeter wave indoor communication systems in Japan," *1993 IEEE MTT-S International Microwave Symposium Digest*, pp. 673-676, 1993.
- [2] M.F. Lei, P.Si. Wu, T.W. Huang, H. Wang, "Design and Analysis of a Miniature W-Band MMIC Subharmonically Pumped Resistive Mixer," *2004 IEEE MTT-S Int. Microwave Sym.*, vol. 1, pp. 235-238, June 2004.
- [3] K.S. Ang, A.H. Baree, S. Nam, I.D. Robertson, "A Millimeter-wave Monolithic Sub-harmonically Pumped Resistive Mixer," *1999 Asia Pacific Microwave Conference*, Vol. 2, pp. 222-225, December 1999.
- [4] K. Kawakami, M. Shimozawa, H. Ikematsu, K. Itoh, Y. Isota, and O. Ishida, "A millimeter-wave broadband monolithic even harmonic image rejection mixer," *1998 IEEE MTT-S Int. Microwave Sym.*, pp. 1443-1446, June 1998.

- [5] M. Yu, Robert H. Walden, A.E. Schmitz, and M. Lui, "Ka/Q-Band Doubly Balanced MMIC Mixers with Low LO Power," *IEEE Microwave and Guided Wave Letters*, vol. 10, no. 10, pp. 424-426, October 2000.
- [6] H. Morkner, S. Kumar, and M. Vice, "A 18-45 GHz Double-Balanced Mixer with Integrated LO Amplifier and Unique Suspended Broadside-Coupled Balun," *2003 Gallium Arsenide Integrated Circuit Symposium*, pp. 267-270, November 2003.
- [7] C.Y. Chang, C.C. Yang, and D.C. Niu, "A Multioctave Bandwidth Rat-Race Singly Balanced Mixer," *IEEE Microwave and Guided Wave Letters*, vol. 9, no. 1, pp. 37-39, January 1999.
- [8] Hittite mixer HMC339 datasheet.
- [9] P. Blount, C. Trantanella, "A High IP3, Subharmonically Pumped Mixer for LMDS Applications" 2000 Gallium Arsenide Integrated Circuit Symposium, pp. 171-174, November 2000.
- [10] H. Okazaki, and Y. Yamaguchi, "Wide-Band SSB Subharmonically Pumped Mixer MMIC," *IEEE Transactions on Microwave Theory and Techniques*, vol. 45, no. 12, pp. 2375-2379, December 1997.
- [11] WIN, Inc., *0.15μm InGaAs pHEMT Power Device Model Handbook*, 2003.
- [12] Applied Wave Research, Inc.
- [13] Sonnet Software Inc., *Sonnet User's Manual, Release 6.0* Liverpool, NY, Apr. 1999.
- [14] M.W. Chapman, S. Raman, "A 60-GHz Uniplanar MMIC 4 × Subharmonic Mixer," *IEEE Transactions on Microwave Theory and Techniques*, vol. 50, no. 11, pp. 2580 – 2588, November 2002.

Reference	Technology	RF(GHz)	CL(dB)	LO (dBm)	Chip size(mm ²)	Mixing type
[4]	GaAs HEMT	24-44	13-16	16	1.2mm × 2.9mm	Subharmonic Anti-parallel
[5]	InP HEMT	30-45	10-14	4	2mm × 2mm	Fundamental, Ring-quad
[6]	GaAs PHEMT	18-45	10-12	17	0.96mm × 0.76mm	Subharmonic Ring-quad
[7]	GaAs	7.5-46	6-10	12	6.35mm × 5.08mm	Fundamental Rat-race ring
[8]	GaAs pHEMT	33-42	10-13	2	0.81mm × 1.34mm	Sub-harmonic
[9]	GaAs	25-40	14	10-16	0.73 × 0.95mm ²	Subharmonic Ring-quad
This work	GaAs PHEMT	38-48	12-15	10	0.85mm × 0.85mm	Subharmonic Anti-parallel

TABLE 1
COMPARISON OF REPORTED DIODE MIXERS